

File MH60484
Project 4786591652

November 26, 2014

REPORT

On

Batteries, Household and Commercial
(BBFS)

Complementary Product Category

Information Technology Equipment
Including Electrical Business Equipment
(NWGQ, NWGQ7)

USC056

Copyright © 2014 UL LLC

UL LLC authorizes the above named company to reproduce this Report only for purposes as described in the Conclusion, provided it is reproduced in its entirety.

DESCRIPTION

PRODUCT COVERED:

USL, CNL - Portable Power Bank, Model(s): PB03, PB05, PB06, SP825.

Basic Model(s)	Derivative Model(s)	Model Differences
PB03	7120-17, 1553, CPP-3791, CU1703, IT800, COMP0248	All Derivative Models are identical to Basic Model except for Model designation
PB05	CPP-3796, CU4909	All Derivative Models are identical to Basic Model except for Model designation
PB06	1558, CPP-3794, CU1528	All Derivative Models are identical to Basic Model except for Model designation
SP825	CPP-3699	All Derivative Models are identical to Basic Model except for Model designation
Remark: PB03, PB05, PB06, SP825 is identical to each other except for model designation, and enclosure, which are specified in Construction Details Descriptive pages.		

ELECTRICAL RATING

Model	Voltage (Nominal)	Capacity (Nominal)	Manufacturer's Recommended Use Ambient
PB03, PB05, PB06, SP825	5.0Vdc	2200mAh	0~45°C for Charging, -20~55°C for Discharging

Note: The packs have been tested based upon their electrical ratings but no capacity performance testing has been conducted. In addition, no testing with a host product including a charger has been conducted.

CELL CHEMISTRY AND CONFIGURATION:

Pack Model	Cell Model	Cell Chemistry and Type#	Number of Cells	Configuration*: X-S/Y-P
PB03, PB05, PB06, SP825	FST18650NB-2200mAh	lithium ion cylindrical	1	1-S/1-P
* - X = No. of cells in series; Y = Number of parallel strings # - e.g. lithium ion cylindrical, lithium ion prismatic, lithium ion polymer (soft pouch), Ni-Cad prismatic, etc.				

MANUFACTURER'S RECOMMENDED CHARGING PARAMETERS:

Model	Standard Charging Current	Standard Charging Voltage	Maximum Charging Current	Maximum Charging Voltage
PB03, PB05, PB06, SP825	550mA	5.0Vdc	600mA	5.3Vdc

GENERAL CONSTRUCTION:

See Section General for general details regarding construction.

TECHNICAL CONSIDERATIONS (NOT FOR FIELD REPRESENTATIVES'S USE):

The output of these battery packs has been determined to be limited power in accordance with second edition of UL 2054 issue dated October 29, 2004 with revisions through and including September 14, 2011.

Products designated USL have been investigated using requirements contained in the First Edition of UL 2054, Standard for Household and Commercial Batteries issue dated October 29, 2004 and contains revisions through and including September 14, 2011.

Products designated USL have been investigated using requirements contained in the U.S. Standard for Safety of Information Technology Equipment-Safety-Part1: General Requirements, UL 60950-1, Second Edition, issue dated March 27, 2007, with revisions through and including October 14, 2014.

Products designated CNL have been investigated using requirements contained in the Canadian Standard for the Safety of Information Technology Equipment-Safety-Part1: General Requirements, Canadian Standards Association, CAN/CSA-C22.2 No. 60950-1-07, second Edition, issue dated March 27, 2007, with revisions through and including October 14, 2014.

MARKINGS/INSTRUCTIONS:

All markings shall be legible and permanent such as ink stamped, etched, adhesive labels, etc. All adhesive labels shall be R/C (PGDQ2) component marking and labeling systems or printed on R/C(PGJI2) Component Printing Materials.

Nameplate Marking - The Listee Name, file number(MH60484), trade name, trademark or other descriptive marking; catalog or model number; electrical rating; date of manufacturer; and UL Listing Mark, UL Listing Mark for Canada.

Date of Manufacturer Marking can be identified as following:

S/N: YYMMXXXXXX or YY-MM-XXXXXX

Where, YY for Year, MM for Month. For example, 1412000000 indicates the Power Bank was manufactured in December, 2014

Factory Location Marking - See Section General for manufacturing location marking.

Cautionary Markings/Instructions - Each 1) battery pack; or 2) the smallest unit package, must be marked with; or 3) instructions provided with each battery, must include the following statements or equivalent:

- a. An attention word such as "CAUTION", "WARNING", or "DANGER", and a brief description of possible hazards associated with mishandling of the battery pack such as burn hazard, fire hazard, explosion hazard, and
- b. A list of actions to take to avoid possible hazards, such as do not crush, disassemble, dispose of in fire, or similar actions.
- c. An attention word such as "Accessible surfaces held or touched for short periods only".

A lithium ion battery pack shall be marked with the following or equivalent: "CAUTION: Risk of Fire and Burns. Do Not Open, Crush, Heat Above (manufacturer's specified maximum temperature) or Incinerate. Follow Manufacturer's Instructions." This wording or equivalent shall also be included in the instructions packaged with the battery pack.

Charging Marking/Instructions - Recommended charging information is also provided on the product, its smallest packaging unit, or the instructions provided with each battery pack.

The charging limits as outlined in the Manufacturer's Recommended Charging Parameters Table above are provided as part of these instructions.

Portable Power Bank, Fig.1 thru Fig.12

See Ill.1 for additional views of overall battery constructions.

1. Cell - See table below:

Battery Pack Model	Cell Manufacturer	Cell Model No.	Recognized Cells, Y or N*	Recognized Cells	
				File No.	Report Date
PB03, PB05, PB06, SP825	JIANGXI FIRST NEW ENERGY CO LTD	FST18650NB-2200mAh	Y	MH48852	2012-06-07

Note: See Cell Chemistry and Configuration Table at beginning of report for information on type of cells, number of cells and their configuration in the battery pack circuit.

Cells are located within the pack in a manner that would not result in blocking of vents in the event of cell venting. Cells are secured in their enclosure and prevented from movement that would cause damage to connections and short circuit of parts by:

Pack Model No.	Description	Cell Layout Ills. No.
PB03, PB05, PB06, SP825	Cell was fitted and secured by enclosure	Fig.1, Fig.2; Fig.5, Fig.7; Fig.8, Fig.9; Fig.10, Fig.11

Connections to cell terminals are constructed as noted below:

Pack Model No.	Description	Ills. No. or description
PB03, PB05, PB06, SP825	Cell was connected to PWB by wires and metal tabs	Fig.2; Fig.7; Fig.9; Fig.11

2. Battery Pack Enclosure/Case - See Table Below:

Battery Pack Model	Overall Dimensions, L x W x H, mm	Minimum thick-ness, mm	Enclosure Material Manufacturer/ Grade	Enclosure Material Type	Enclosure material flame rating at Minimum Thickness*
PB03	Approximately 91.6*25.4*25.4	0.75 (Inner Case and Side Cap)	SABIC (E45329, E121562 or E207780)	CX7240 (GG)	V-0, 90°C
		1.0 (Outer Transparent Case)	Various	Various	HB, 80°C
PB05	Approximately 96.8*24.6*22.0	0.75 (Snap-fit Frame)	SABIC (E45329, E121562 or E207780)	CX7240 (GG)	V-0, 90°C
		0.5 (Outer Plate)	Various	Various	HB, 80°C
PB06	Approximately 92*21.8 (diameter)	1.0 (Screw thread-fit Case)	--	Aluminum Material	--
		0.75 (Plastic Cap)	SABIC (E45329, E121562 or E207780)	CX7240 (GG)	V-0, 90°C
SP825	Approximately 96.6*26.7 (diameter)	0.75 (Inner Case and Side Cap)	SABIC (E45329, E121562 or E207780)	CX7240 (GG)	V-0, 90°C
		1.0 (Outer Transparent Case)	Various	Various	HB, 80°C

* - V-0, V-1, or compliant with UL746C 20mm Flame Test

Battery Pack Enclosures are secured by:

Battery Pack Model	Parts assembling	Secured material Description	Ills. No.
PB03	Secured by Special Screw	--	Fig.2, Fig.12
PB05	Snap-fit and secured by Adhesive	Polymeric Adhesive Systems - R/C (QOQW2), Min. -20~60°C	Fig.7
*PB06	Screw thread-fit and secured by Pipe Joint Sealing Compounds	TYPE: 271 , Pipe Joint Sealing Compounds, by HENKEL CORP (MH8007)	Fig.9
SP825	Snap-fit and secured by Adhesive	Polymeric Adhesive Systems - R/C (QOQW2), Min. -20~60°C	Fig.11

3. Protective Circuitry - Consists of the following:

Battery Pack Model No.	Type of Protective Component	Location of Component Within Pack	Component Manufacturer	Component Part No.	Component Ratings
PB03, PB05, PB06, SP825	IC (U1)	PWB	VIIHOT	VT5017	--
	IC (U3)	PWB	VIIHOT	VT5353	--
	IC (U2)	PWB	Fitipower integrated technology Inc	FP6715	--
	Inductor (L1)	PWB	Various	Various	3.3uH 1.5A

See the following illustrations for details of protective circuitry:

Battery Pack Model Number	Illustration Number
PB03	Ill.5
PB05	Ill.6
PB06	Ill.7
SP825	Ill.7

4. External Connector - Constructed as noted below:

Battery Pack Model Number	R/C Connector Manufacturer	R/C Connector Part Number	Illustration No. or description
PB03, PB05, PB06, SP825	--	--	USB port

5. Insulation (Optional) - R/C (OANZ2), located between cell and other parts, minimum 105 degree C or designated "Flame Retardant". Except for less than or equal to 2 cm3.
6. Printed Wiring Board - R/C (ZPMV2), Min. V-1, Min. 105°C.
7. Lead Wires - - R/C (AVLV2), Routed away from sharp edges, moving parts. Rated minimum 80 degree C, 30 V, minimum 24 AWG, FEP, PTFE, PVC, TFE, neoprene, or surface marked VW-1 or FT-1.
8. Heat Shrinkable PVC (Optional) - R/C (YDQS2 or YDPU2), marked minimum VW-1 or FT-1, 105 deg C.

FIGURES:

Fig. No.	Model
1	Overall View - Model PB03
2	Internal View 1 - Model PB03
3	Internal View 2 - Model PB03
4	Internal View 3 - Model PB03
5	Overall View - Model PB05
6	Internal View 1 - Model PB05
7	Internal View 1 - Model PB05
8	Overall View - Model PB06
9	Internal View- Model PB06
10	Overall View - Model SP825
11	Internal View - Model SP825
12	Special Screw - Model PB03

ILLUSTRATIONS:

ILL. No.	Description
1	Enclosure Drawing for Model PB03
2	Enclosure Drawing for Model PB05
3	Enclosure Drawing for Model PB06
4	Enclosure Drawing for Model SP825
5	PWB Layout for Model PB03
6	PWB Layout for Model PB05
7	PWB Layout for Model PB06, SP825

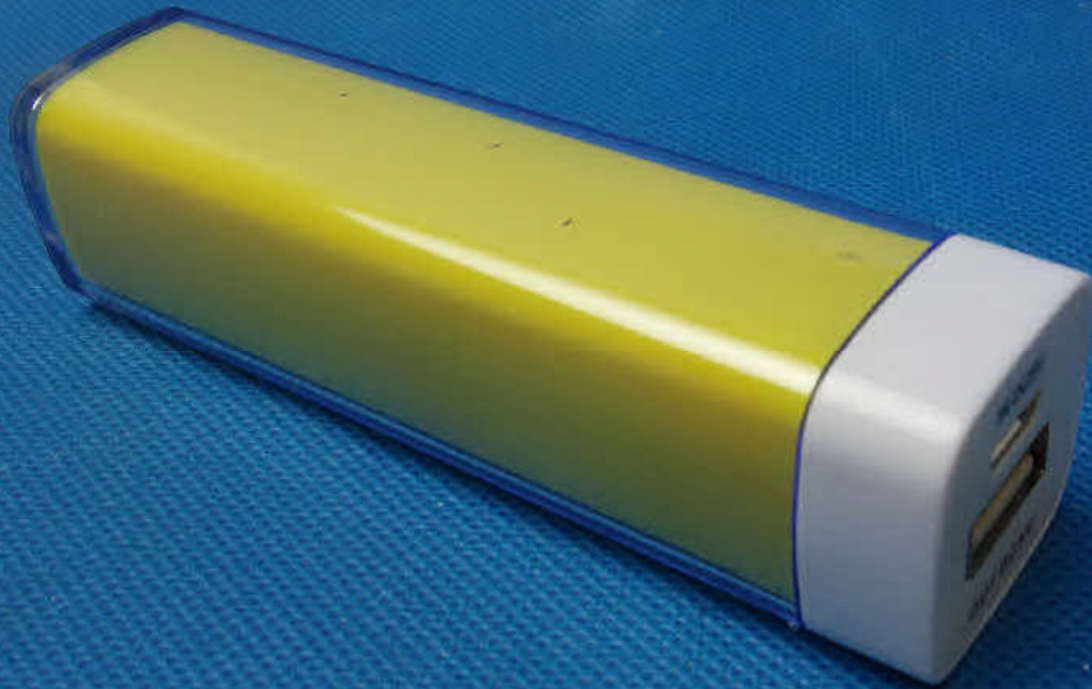

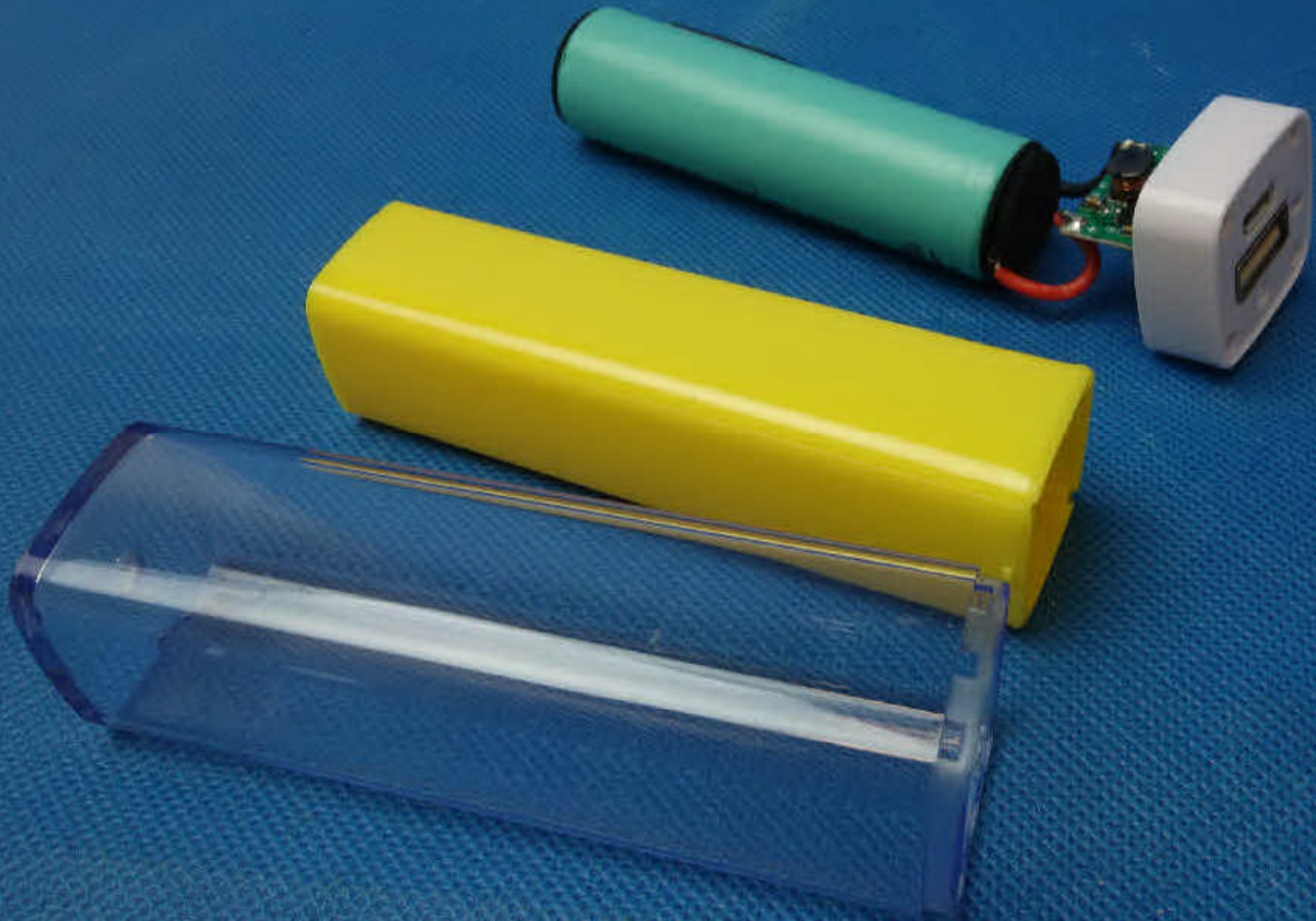

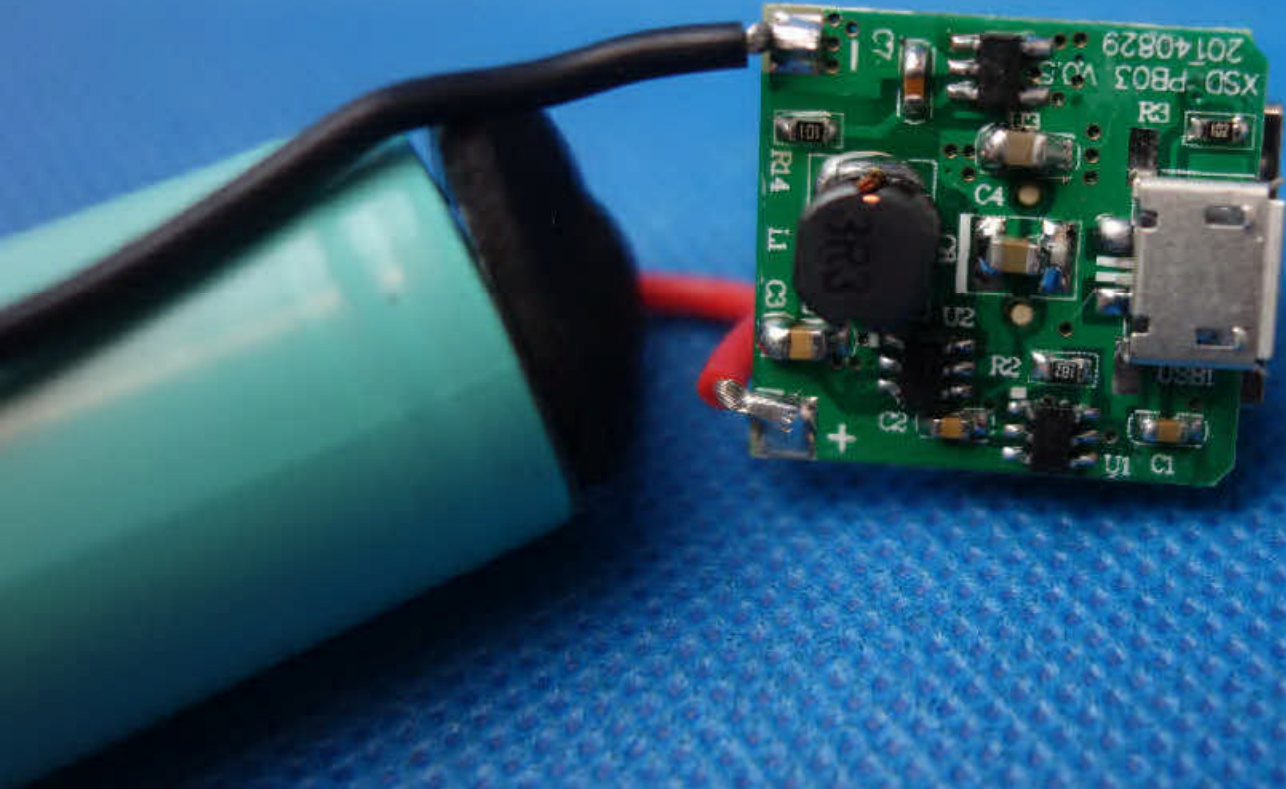

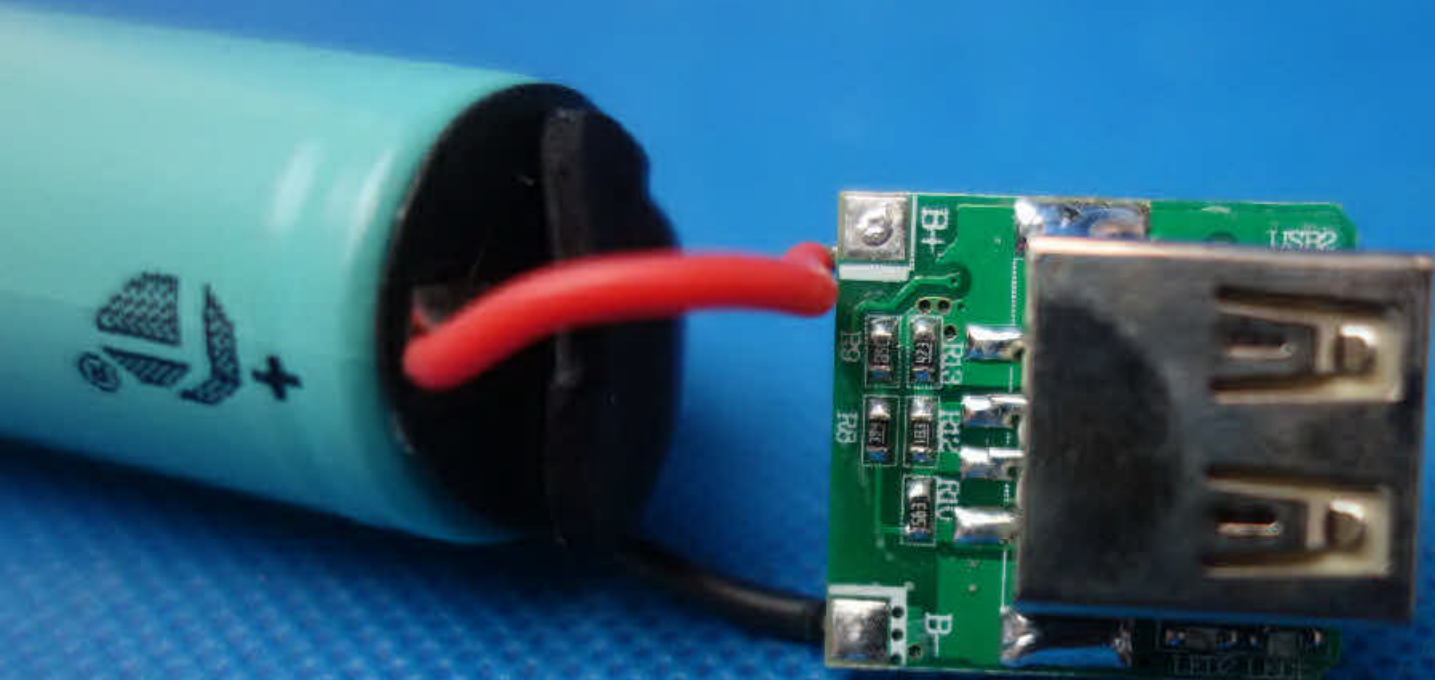

















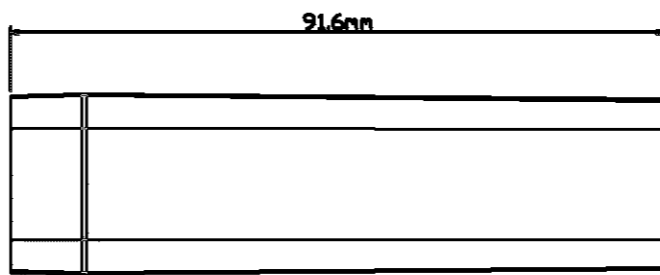
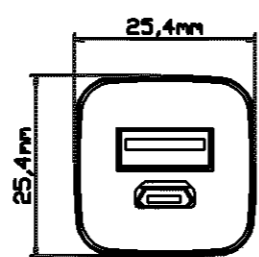
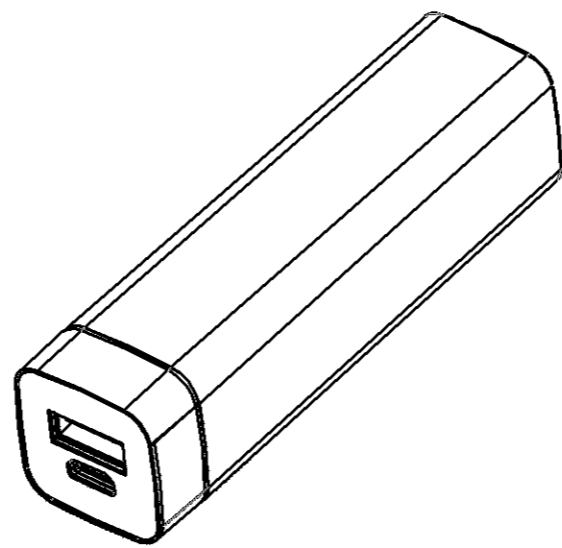

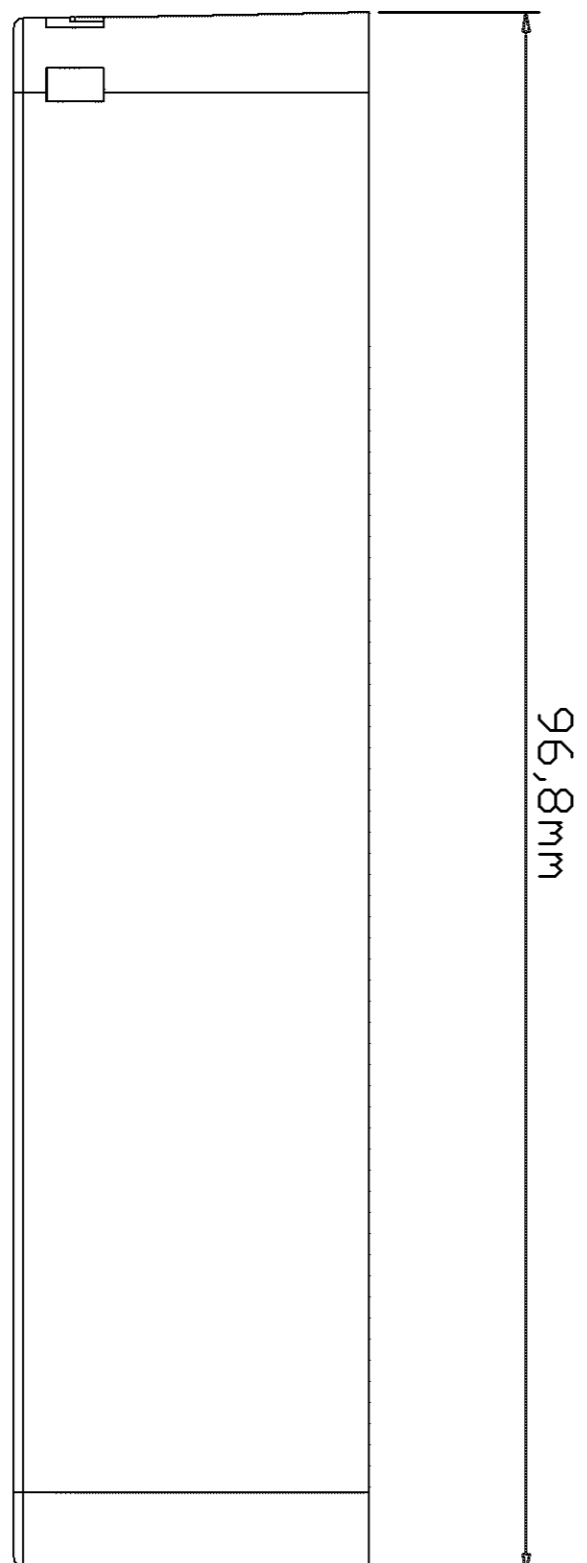
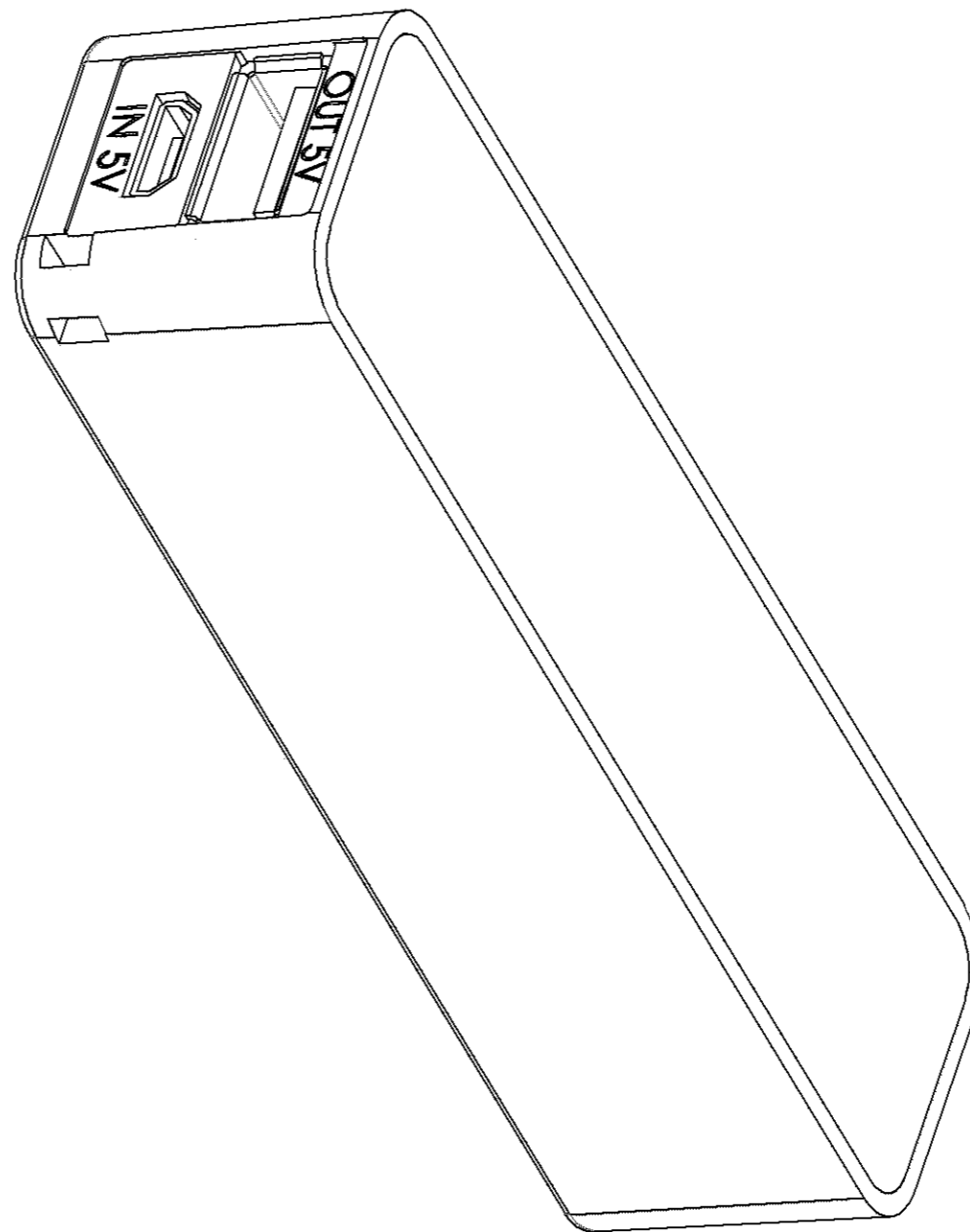
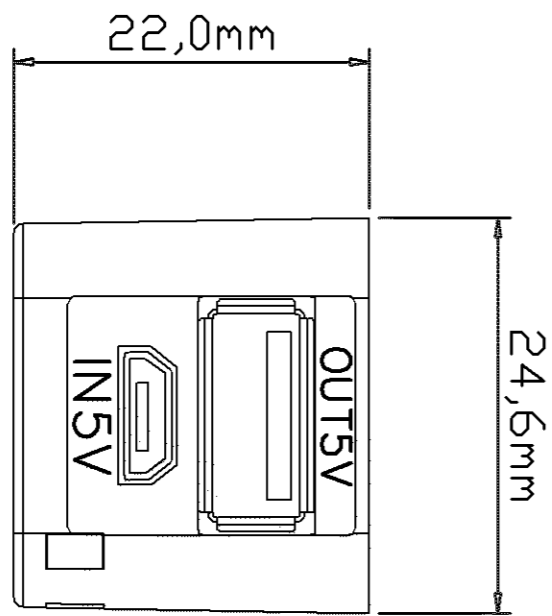

Unit: mm

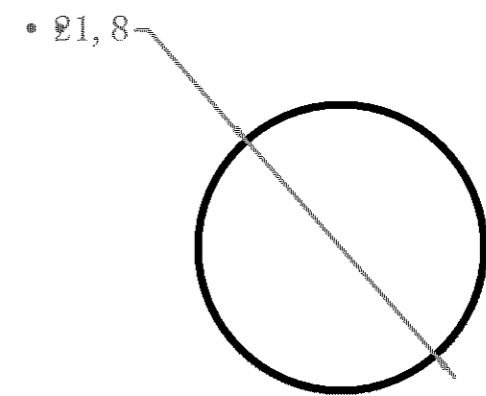
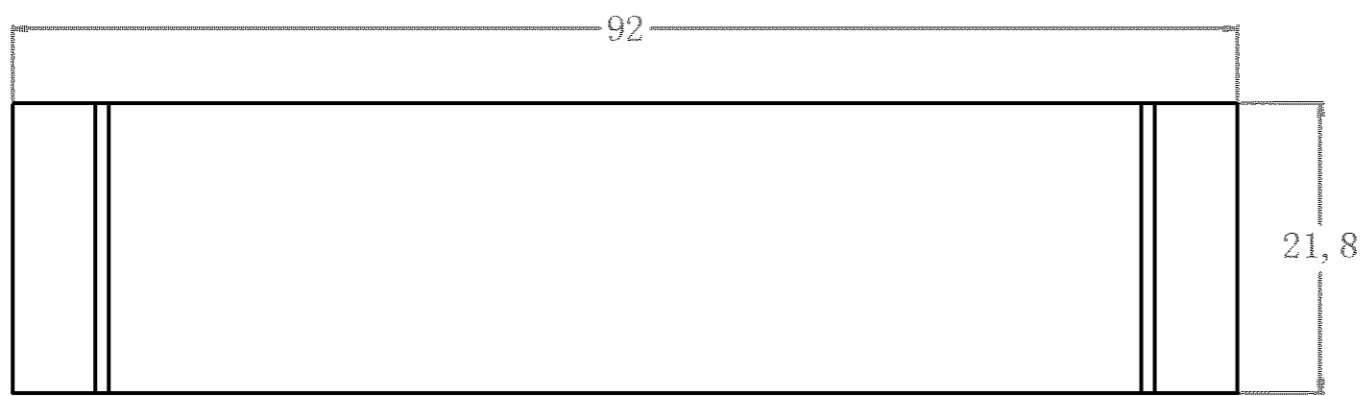

SP825外部尺寸图:

File: MP160484

Vol. 1 Sec. 2 ILL-4
and Report

Issued: 2014-11-26

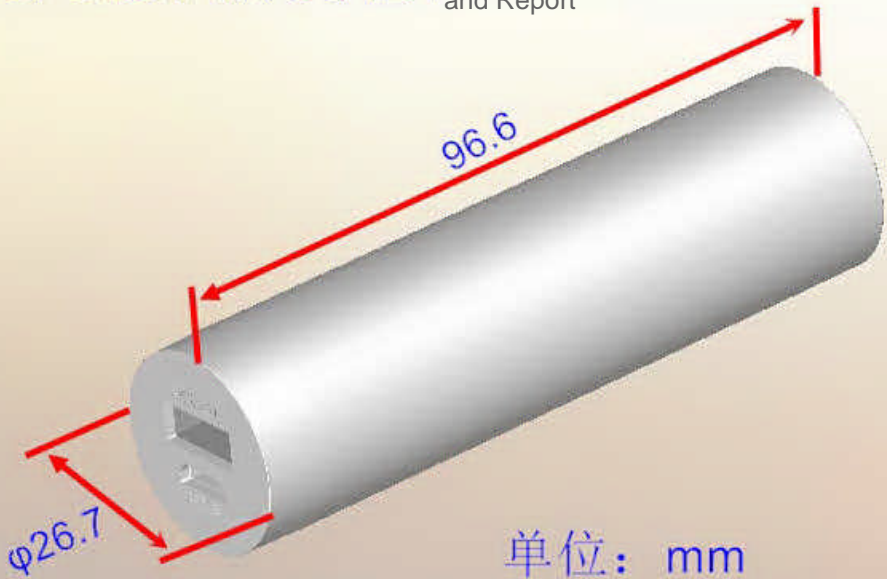

单位: mm

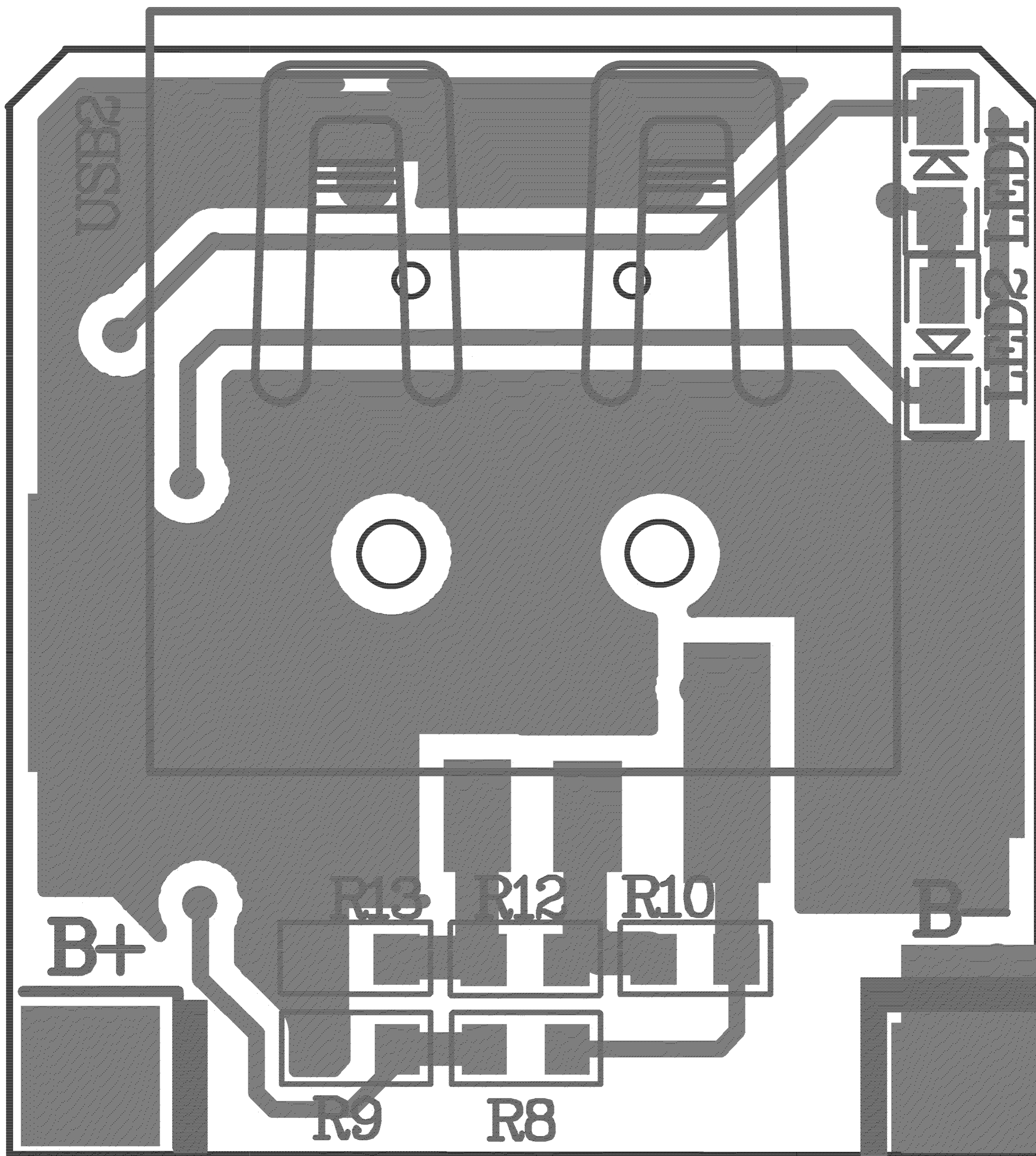

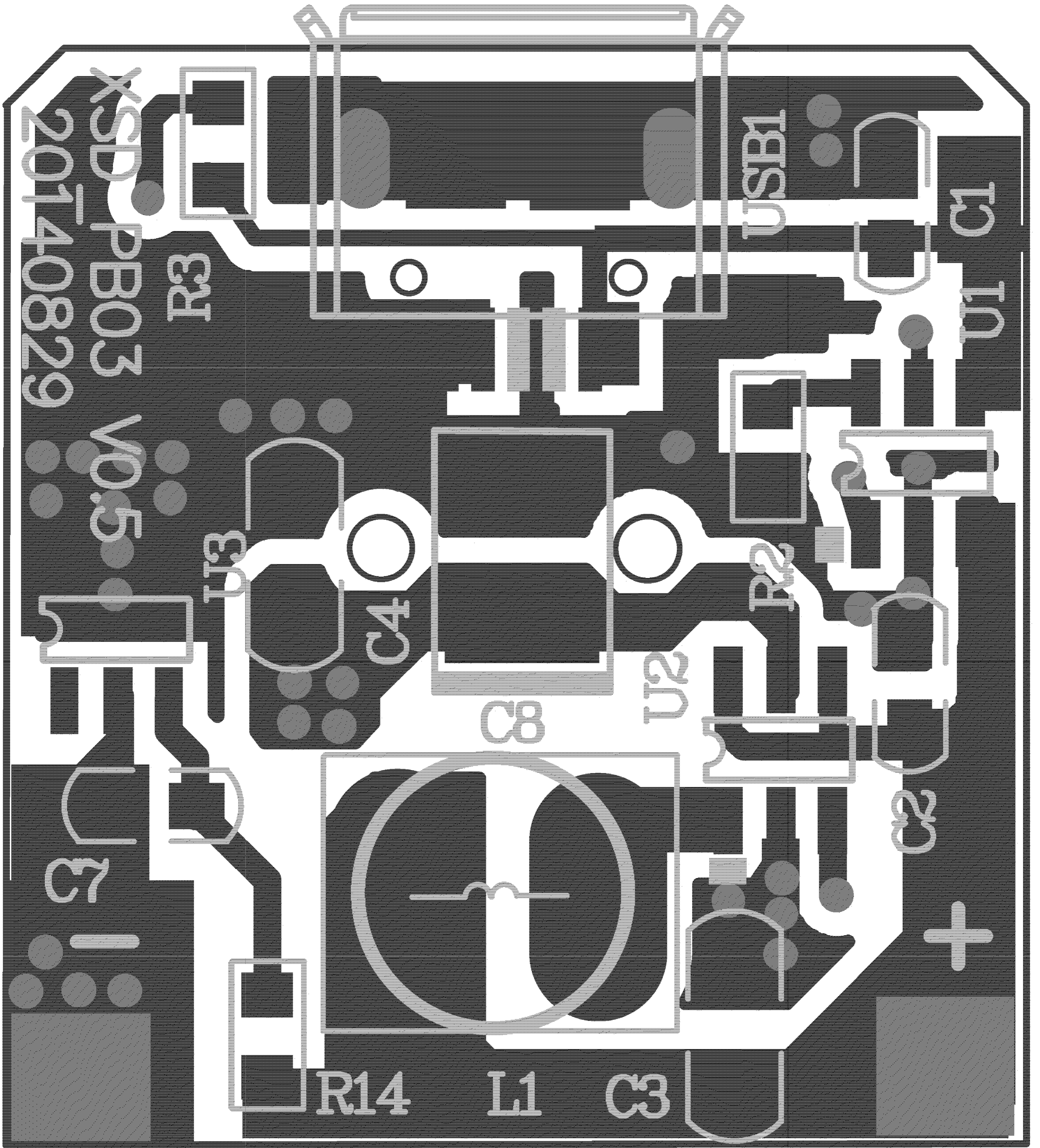

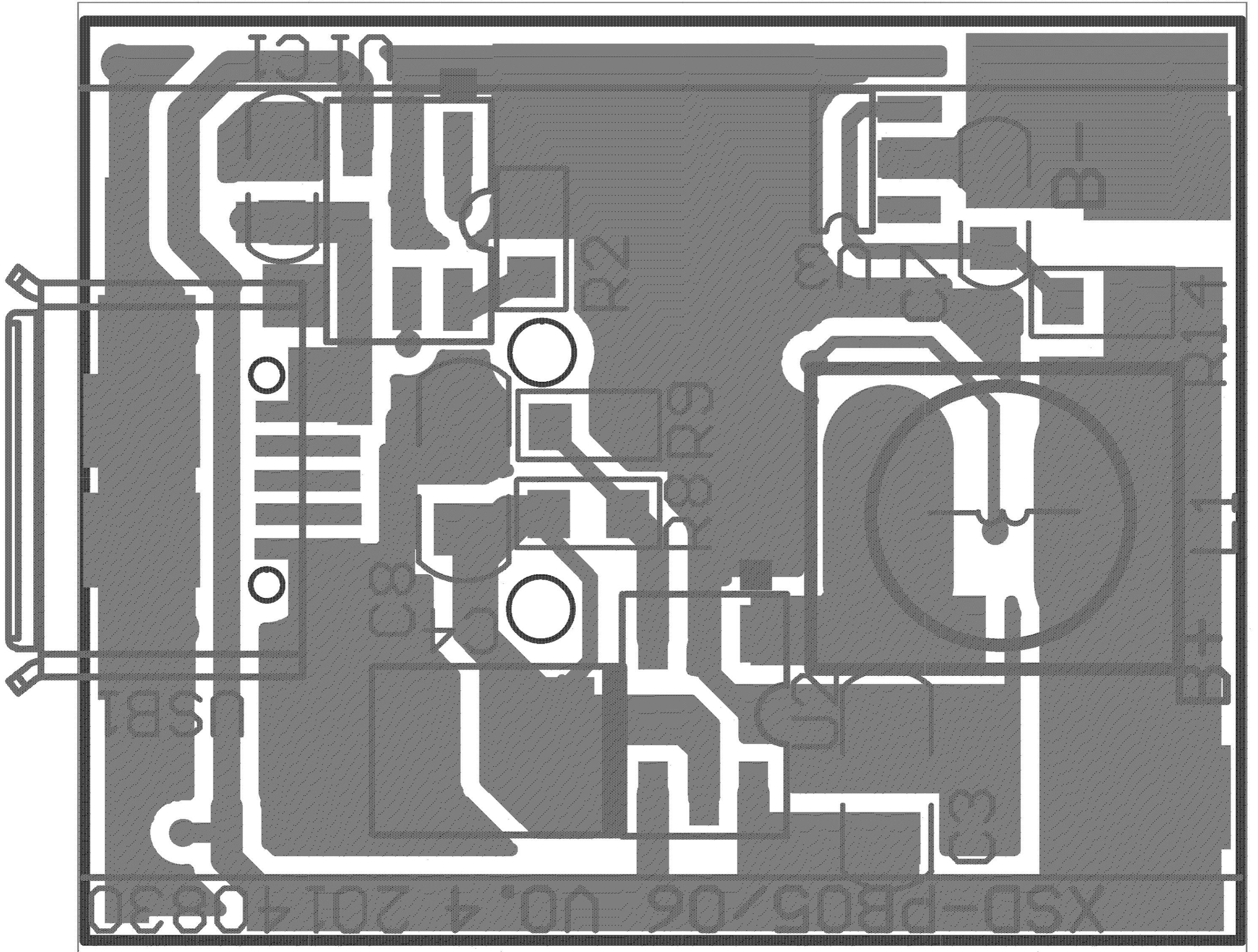

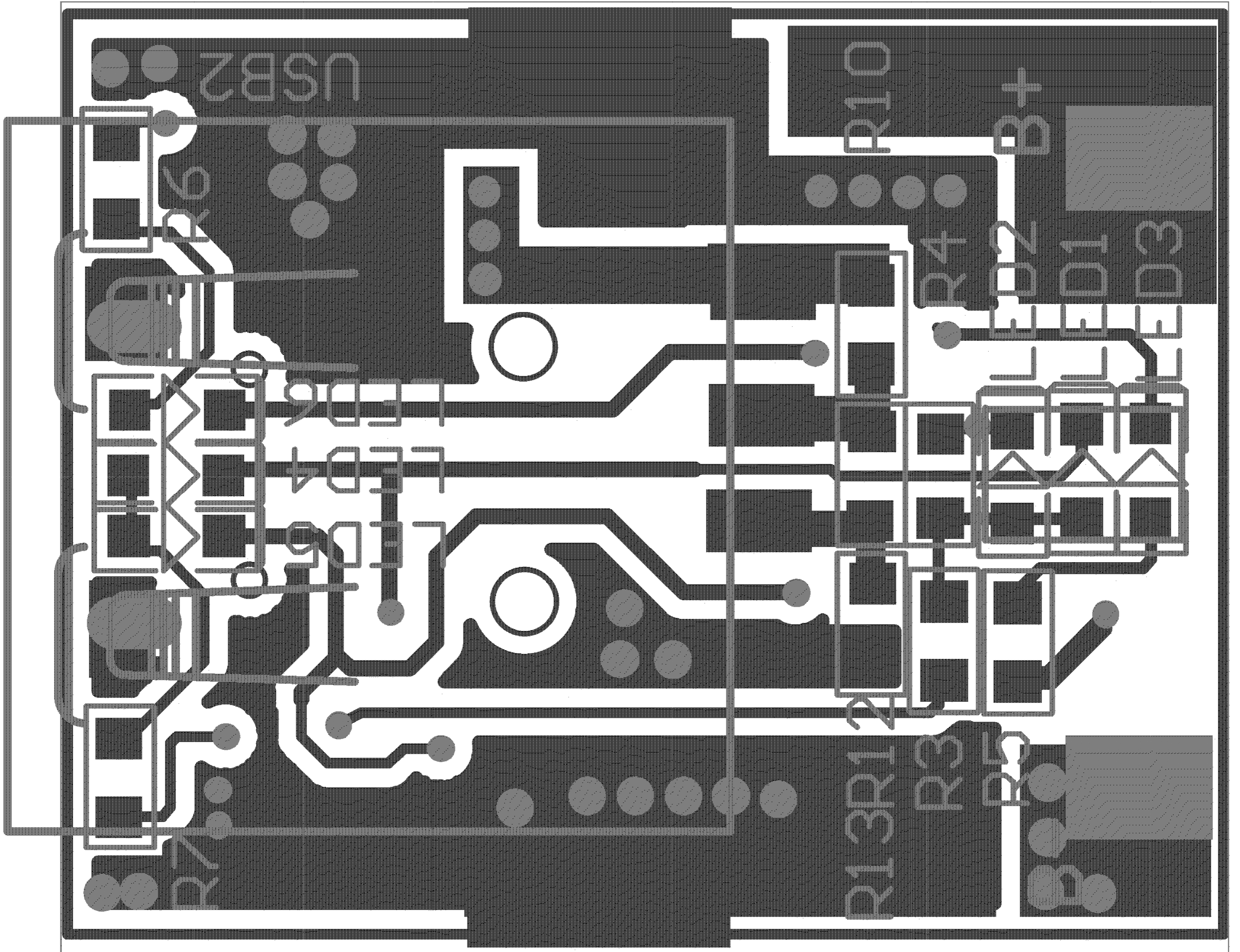

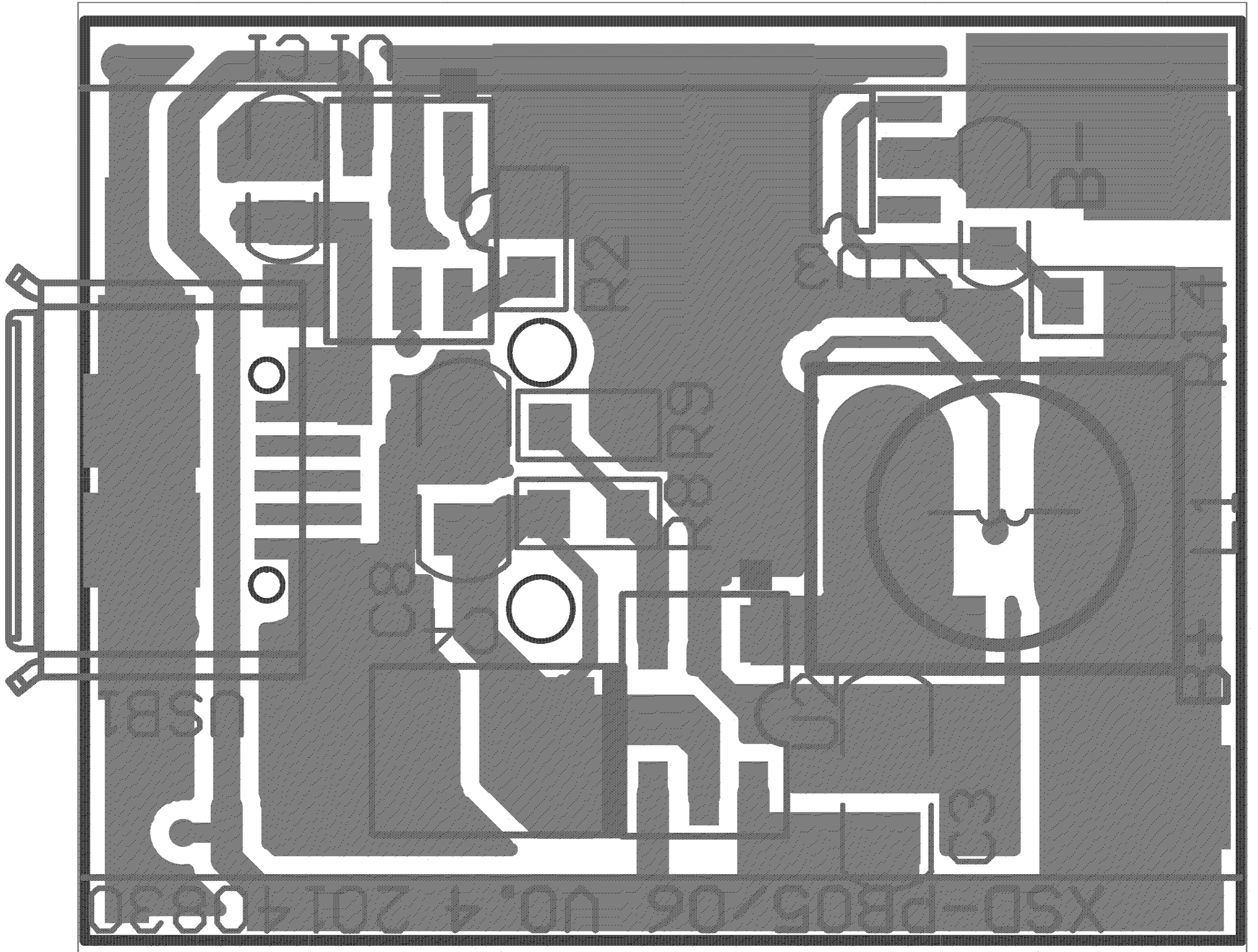

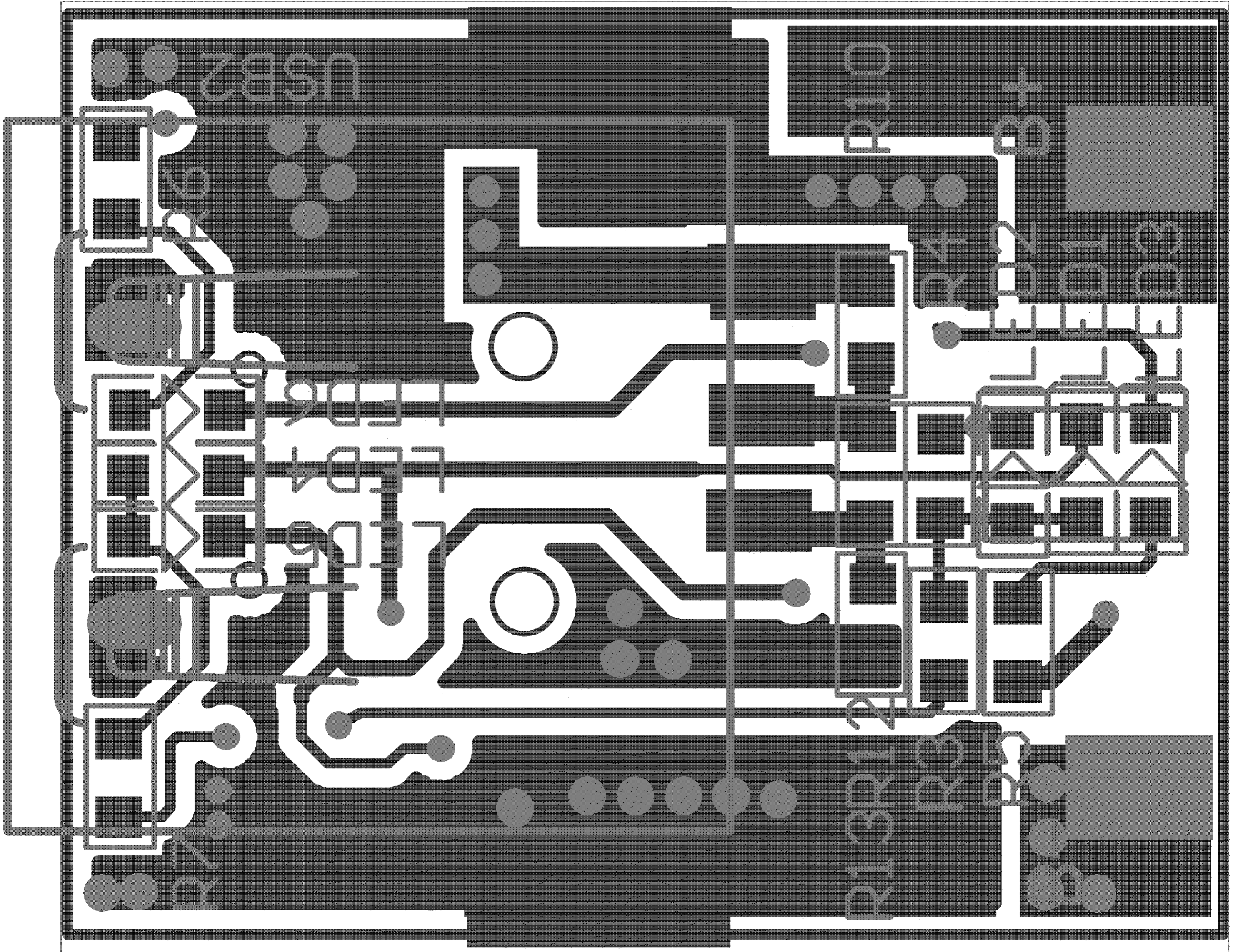

TEST RECORD NO. 1

SAMPLES:

Samples Portable Power Bank, Models as indicated below and constructed as described herein, was submitted by the manufacturer for examination and test.

Model No.	Nominal Voltage, V dc	Capacity, Ah	Maximum Charging Voltage, V dc	Maximum Charging Current, mA	Maximum discharge condition, mA	Dis-charge Cutoff Voltage, Vdc	Cell Config xS/yP	Cell Mfg.	Cell Model Number
PB03, PB05, PB06, SP825	5.0	2.2	5.3	600	1200	2.75 (Cell)	1S/1P	JIANGXI FIRST NEW ENERGY CO LTD (MH48852)	FST18650NB-2200mAh

GENERAL:

Test results relate only to the items tested.

All tests are conducted at UL-CCIC Company Limited Guangzhou Branch.

Models PB03, PB05, PB06, SP825 is identical to each other except for model designation and enclosure, full tests need conduct on Model PB05, and simplified tests on Models PB03, PB06, SP825, as following:

Model (s)	Test Conducted	UL 2054 Section Reference / [x] (UL/CSA 60950-1 Section Reference)	Compliant Results? [Y] [N]	Comments
PB05	Short Circuit Test - At Room Temperature (Excessive Discharging Rate for any Battery)	9.7 - 9.12 (4.3.8)	Y	--
PB05	Short Circuit Test - At 55 C	9.7 - 9.12	Y	--
PB05	Abnormal Charging Test: (Secondary) (Overcharging of a Rechargeable Battery)	10.10 - 10.13 (4.3.8)	Y	--
PB05	Abusive Overcharge Test	11	Y	--
PB05	Limited Power Source Test	13 (2.5)	Y	--

Table Cont'd

Model(s)	Test Conducted	UL 2054 Section Reference / [x] (UL/CSA 60950-1 Section Reference)	Compliant Results? [Y] [N]	Comments
PB03, PB05, PB06, SP825	Battery Pack Component Temperature Test Lithium Ion System (Heating Test) (Energy Hazard Measurements)	13A 4.5 (4.5) (2.1.1.5)	Y	--
PB03, PB05, PB06, SP825	Battery Pack Surface Temperature Test (Heating Test)	13B (4.5)	Y	--
PB03, PB05, PB06, SP825	250 N Steady Force Test (Steady Force Tests - 250 N)	19 (4.2.4)	Y	--
PB03, PB05, PB06, SP825	Mold Stress Relief Test (Stress Relief)	20 (4.2.7)	Y	--
PB03, PB05, PB06, SP825	Drop Impact Test (Drop)	21 (4.2.6)	Y	--

The test methods and results of the above tests have been reviewed and found in accordance with the requirements (unless noted otherwise in the table above) in the Standard for Household and Commercial Batteries, UL 2054, Second Edition, including revisions through revision date September 14, 2011.

The test methods and results of the above tests also have been reviewed and found in accordance with the requirements (unless noted otherwise in the table above) in the U.S. and Canadian (Bi-National) Standard for Safety of Information Technology Equipment-Safety-Part1: General Requirements, CAN/CSA-C22.2 No. 60950-1-07, Second Edition, issue dated October 14, 2014, and UL 60950-1, Second Edition, including revisions through revision date October 14, 2014.

Test Record Summary:

The results of this investigation, including construction review and testing, indicate that the products evaluated comply with the applicable requirements in the U.S. Standard for Safety of Household and commercial Batteries, UL 2054 Second Edition, including revisions through revision date September 14, 2011, and the U.S. and Canadian (Bi-National) Standard for Safety of Information Technology Equipment-Safety-Part1: General Requirements, CAN/CSA-C22.2 No. 60950-1-07, Second Edition, issue dated October 14, 2014, and UL 60950-1, Second Edition, including revisions through revision date October 14, 2014, and, therefore, such products are judged eligible to bear UL's Mark as described on the Conclusion Page of this Report.

CONCLUSION

Samples of the product covered by this Report have been found to comply with the requirements covering the category and the product is found to comply with UL's applicable requirements. The description and test result in this Report are only applicable to the sample(s) investigated by UL and does not signify UL certification or that the product(s) described are covered under UL's Follow-Up Service Program. When covered under UL's Follow-Up Service Program, the manufacturer is authorized to use the UL Listing on such products which comply with UL's Follow-Up Service Procedure and any other applicable requirements of UL LLC. The Listing Mark of UL LLC on the product, or the UL symbol on the product and the Listing Mark on the smallest unit container in which the product is packaged, is the only method to identify products investigated by UL to published requirements and manufactured under UL's Listing and Follow-Up Service.

This Report is intended solely for the use of UL LLC (UL) and the Applicant for establishment of UL certification coverage of the described product(s) under UL's Follow-Up Service. UL retains all rights, title and interest (including exclusive ownership) in this Report and all copyright therein. The Applicant or its designated agent shall not disclose or otherwise distribute this Report or its contents to any third party, except as required for purposes of compliance with laws, regulations, or other existing agreements or schemes in which UL is currently a participant. Any other use of this Report including, without limitation, evaluation or certification by a party other than UL is prohibited and renders the Report null and void. UL shall not incur any obligation or liability for any loss, expense, or punitive damages, arising out of, or in connection with, the use or reliance upon the contents of this Report to anyone other than the Applicant as provided in the agreement between UL and Applicant. Any use or reference to UL's name or certification mark(s) by anyone other than the Applicant in accordance with the agreement is prohibited without the express written approval of UL. Any information and documentation involving UL Mark services are provided on behalf of UL LLC (UL) or any authorized licensee of UL. UL shall not otherwise be responsible to anyone for the use of or reliance upon the contents of this Report.

Report by:

NICKY X. WU
Engineer Project Associate