

Certificate of Conformity

NO.: ED170410042E

The following product has been tested by us with the listed standards and found in conformity with the council EMC directive 2014/30/EU. It is possible to use CE marking to demonstrate the conformity with this EMC Directive.

Applicant : USC056

Address :
USC056

Manufacturer : N/A

Address : Micro Tru Wireless Earbuds & Powercase
7199-99, PO-FN1628-00188, 10830500

Trade Mark : EN 55032: 2015
EN 61000-3-2: 2014

EUT : EN 61000-3-3: 2013
EN 55024: 2010+A1: 2015

M/N :

Test Standards :



April 18, 2017

The certificate is based on a single evaluation of one sample of above-mentioned products. It does not imply an assessment of the whole production and does not permit the use of the test lab. logo.

EMC TEST REPORT

For

USC056

LTD Micro TruWireless Earbuds & Powercase

Model No.: 7199-99, PO-FN1628-00188, 10830500

Prepared for : USC056
Address :

Prepared By : EMTEK(DONGGUAN) CO., LTD.
Address : No.281, Guantai Road, Nancheng District, Dongguan,
Guangdong, China
Tel : +86-769-22807078
Fax: +86-769-22807079

Report Number : ED170410042E
Date of Test : April 10, 2017 to April 14, 2017
Date of Report : April 18, 2017

TABLE OF CONTENTS

1. DESCRIPTION OF STANDARDS AND RESULTS	6
2. GENERAL INFORMATION	7
2.1 Description of Device (EUT)	7
2.2 Description of Support Device	7
2.3 Description of Test Facility	8
2.4 Measurement Uncertainty	9
3. MEASURING DEVICES AND TEST EQUIPMENT	10
3.1 For Power Line Conducted Emission	10
3.2 For Radiated Emission Measurement	10
3.3 For Harmonic / Flicker Measurement	10
3.4 For Electrostatic Discharge Test	10
3.5 For RF Strength Susceptibility Test	11
3.6 For Electrical Fast Transient/Burst Immunity Test	11
3.7 For Surge Test	11
3.8 For Injected Currents Susceptibility Test	11
3.9 For Magnetic Field Immunity Test	11
3.10 For Voltage Dips and Interruptions Test	11
4. POWER LINE CONDUCTED MEASUREMENT	12
4.1 Block Diagram of Test Setup	12
4.2 Conducted Power Line Emission Measurement Standard and Limits	12
4.3 EUT Configuration on Measurement	12
4.4 Operating Condition of EUT	13
4.5 Test Procedure	13
4.6 Measurement Results	13
5. RADIATED EMISSION MEASUREMENT	16
5.1 Block Diagram of Test	16
5.2 Measuring Standard	16
5.3 Radiated Emission Limits	17
5.4 EUT Configuration on Test	17
5.5 Operating Condition of EUT	17
5.6 Test Procedure	17
5.7 Test Results	17
6. HARMONIC CURRENT MEASUREMENT	20
6.1 Block Diagram of Test Setup	20
6.2 Measuring Standard	20
6.3 Operating Condition of EUT	20
6.4 Test Results	20
7. VOLTAGE FLUCTUATIONS & FLICKER MEASUREMENT	21
7.1 Block Diagram of Test Setup	21
7.2 Measuring Standard	21
7.3 Operating Condition of EUT	21
7.4 Test Results	21
8. ELECTROSTATIC DISCHARGE TEST	23
8.1 Block Diagram of Test Setup	23
8.2 Test Standard	23
8.3 Severity Levels and Performance Criterion	24
8.4 EUT Configuration	24
8.5 Operating Condition of EUT	24
8.6 Test Procedure	25
8.7 Test Results	25
9. RF FIELD STRENGTH SUSCEPTIBILITY TEST	27

9.1 Block Diagram of Test Setup.....	27
9.2 Test Standard	27
9.3 Severity Levels and Performance Criterion.....	28
9.4 EUT Configuration.....	28
9.5 Operating Condition of EUT.....	28
9.6 Test Procedure	28
9.7 Test Results	29
10. ELECTRICAL FAST TRANSIENT/BURST TEST	31
10.1 Block Diagram of Test Setup.....	31
10.2 Test Standard	31
10.3 Severity Levels and Performance Criterion	32
10.4 EUT Configuration	32
10.5 Operating Condition of EUT	32
10.6 Test Procedure	33
10.7 Test Results	33
11. SURGE IMMUNITY TEST	35
11.1 Block Diagram of Test Setup.....	35
11.2 Test Standard	35
11.3 Severity Levels and Performance Criterion	36
11.4 EUT Configuration	36
11.5 Operating Condition of EUT	36
11.6 Test Procedure	36
11.7 Test Results	36
12. INJECTED CURRENTS SUSCEPTIBILITY TEST	38
12.1 Block Diagram of Test Setup.....	38
12.2 Test Standard	38
12.3 Severity Levels and Performance Criterion	39
12.4 EUT Configuration	39
12.5 Operating Condition of EUT	39
12.6 Test Procedure	39
12.7 Test Results	40
13. VOLTAGE DIPS AND INTERRUPTIONS TEST	42
13.1 Block Diagram of Test Setup.....	42
13.2 Test Standard	42
13.3 Severity Levels and Performance Criterion	43
13.4 EUT Configuration	43
13.5 Operating Condition of EUT	43
13.6 Test Procedure	43
13.7 Test Results	43
14. PHOTOGRAPH	45
14.1 Photo of Conducted Emission Measurement	45
14.2 Photo of Radiation Emission Measurement.....	45
14.3 Photo of Harmonic/Flicker Measurement.....	46
14.4 Photo of Electrostatic Discharge Test.....	46
14.5 Photo of RF Field Strength susceptibility Test	47
14.6 Photo of Electrical Fast Transient /Burst Test	47
14.7 Photo of Surge Test.....	48
14.8 Photo of Injected Currents Susceptibility Test.....	48
14.9 Photo of Voltage Dips and Interruption Immunity Test.....	49
Appendix I (Photos of EUT) (7 pages)	

TEST REPORT DESCRIPTION

Applicant : USC056
Manufacturer : Micro TruWireless Earbuds & Powercase
EUT : 7199-99, PO-FN1628-00188, 10830500
Model No. : DC 5V from adapter, Battery 3.7V
Input Rating :

Measurement Procedure Used:

EN 55032: 2015
EN 61000-3-2: 2014, EN 61000-3-3: 2013
EN 55024: 2010+A1: 2015
(IEC 61000-4-2: 2008, IEC61000-4-3: 2006+A1:2007+A2: 2010, IEC 61000-4-4: 2012,
IEC 61000-4-5: 2014, IEC 61000-4-6: 2013, IEC 61000-4-11: 2004)

The device described above is tested by EMTEK(DONGGUAN) CO., LTD. and EMTEK (SHENZHEN) CO., LTD. to determine the maximum emission levels emanating from the device and the severe levels of the device can endure and its performance criterion. The measurement results are contained in this test report and EMTEK(DONGGUAN) CO., LTD. is assumed full responsibility for the accuracy and completeness of these measurements. Also, this report shows that the EUT to be technically compliant with the EN55032, EN61000-3-2, EN61000-3-3 and EN55024 requirements.

This report applies to above tested sample only and shall not be reproduced in part without written approval of EMTEK(DONGGUAN) CO., LTD.

Date of Test : April 10, 2017 to April 14, 2017

Prepared by : Abby Li
Abby Li/ Editor

Reviewer : Alan He
Alan He/ Supervisor

Approved & Authorized Signer : Sam Lv
Sam Lv/ Manager*

Modified Information

Version	Summary	Revision Date	Report No.
Ver. 1.0	Original Report	/	ED170410042E

1. DESCRIPTION OF STANDARDS AND RESULTS

EMISSION			
Description of Test Item	Standard	Limits	Results
Conducted Disturbance at Mains Terminals	EN 55032: 2015	Clause 5	Pass
Radiated Disturbance	EN 55032: 2015	Clause 5	Pass
Harmonic Current Emissions	EN 61000-3-2:2014	Class A	N/A
Voltage Fluctuation and Flicker	EN 61000-3-3: 2013	Clause 5	Pass
IMMUNITY			
Description of Test Item	Basic Standard	Performance Criteria	Results
Electrostatic Discharge (ESD)	IEC 61000-4-2: 2008	B	Pass
Radio-Frequency, Continuous Radiated Disturbance	IEC 61000-4-3: 2006 +A1: 2007+A2: 2010	A	Pass
EFT/B Immunity	IEC 61000-4-4: 2012	B	Pass
Surge Immunity	IEC 61000-4-5: 2014	B	Pass
Conducted RF Immunity	IEC 61000-4-6: 2013	A	Pass
Voltage Dips, >95% Reduction	IEC 61000-4-11: 2004	B	Pass
Voltage Dips, 30% Reduction		C	Pass
Voltage Interruptions		C	Pass
Note: N/A is an abbreviation for Not Applicable.			

2. GENERAL INFORMATION

2.1 Description of Device (EUT)

EUT	: Micro TruWireless Earbuds & Powercase
Model Number	: 7199-99, PO-FN1628-00188, 10830500 (note: The models are the same except appearance and model number, so we prepare 7199-99 for the EMC test.)
Trade Mark	: N/A
Power Supply for Test	: AC 230V/50Hz for adapter
Highest internal frequency	: 2480MHz
Operate Mode	: Charging
Applicant	: USC056
Address	:
Manufacturer	: USC056
Address	:
Date of sample receiver	: April 10, 2017
Date of Test	: April 10, 2017 to April 14, 2017

2.2 Description of Support Device

Adapter	: Model : YSV6-0501000 Input: AC 100-240V, 50/60Hz Output: DC 5V, 1000mA
---------	--

2.3 Description of Test Facility

Site Description

EMC Lab

: Accredited by CNAS, 2015.09.24
The certificate is valid until 2018.07.03
The Laboratory has been assessed and proved to be in compliance with CNAS/CL01:2006
The Certificate Registration Number is L3150

Accredited by TUV Rheinland, 2016.02.02

The certificate is valid until 2017.02.01

The Laboratory has been assessed according to the requirements ISO/IEC 17025: 2005

Registered on FCC, June 18, 2014

The Certificate Number is 247565.

Registered on Industry Canada, February 19, 2014

The Certificate Number is 9444A

Name of Firm

: EMTEK(DONGGUAN) CO., LTD.

Site Location

: No.281, Guantai Road, Nancheng District, Dongguan, Guangdong, China.

2.4 Measurement Uncertainty

Test Item	Uncertainty
Conducted Emission Uncertainty	: 2.42dB
Disturbance Power	: 2.86dB
Radiated Emission Uncertainty (3m Chamber)	: 3.45dB (30M~1GHz Polarize: H) 3.32dB (30M~1GHz Polarize: V) 3.7dB (1~18GHz Polarize: H) 3.6dB (1~18GHz Polarize: V)
Uncertainty for Flicker test	: 0.07%
Uncertainty for Harmonic test	: 1.8%
Uncertainty for C/S Test	: 1.45(Using CDN Test) 2.37(Using EM Clamp Test)
Uncertainty for R/S Test	: 2.10dB(80MHz-200MHz) 1.76dB(200MHz-1000MHz)
Uncertainty for test site temperature and humidity	: 0.6°C 4%

3. MEASURING DEVICES AND TEST EQUIPMENT

3.1 For Power Line Conducted Emission

Item	Equipment	Manufacturer	Model No.	Serial No.	Last Cal.	Cal. Interval
1.	Test Receiver	Rohde&Schwarz	ESCI	100137	May 16, 2016	1 Year
2.	L.I.S.N.	Rohde&Schwarz	ENV216	100017	May 16, 2016	1 Year
3.	RF Switching Unit	CDS	RSU-M2	38401	May 16, 2016	1 Year

3.2 For Radiated Emission Measurement

Item	Equipment	Manufacturer	Model No.	Serial No.	Last Cal.	Cal. Interval
1.	Test Receiver	Rohde & Schwarz	ESCI	100137	May 16, 2016	1 Year
2.	Bilog Antenna	Schwarzbeck	VULB9163	000141	May 16, 2016	1 Year
3.	Power Amplifier	CDS	RSU-M352	818	May 16, 2016	1 Year
4.	Power Amplifier	HP	8447F	OPT H64	May 16, 2016	1 Year
5.	Color Monitor	SUNSPO	SP-140A	N/A	May 16, 2016	1 Year
6.	Single Line Filter	JIANLI	XL-3	N/A	May 16, 2016	1 Year
7.	Single Phase Power Line Filter	JIANLI	DL-2X100B	N/A	May 16, 2016	1 Year
8.	3 Phase Power Line Filter	JIANLI	DL-4X100B	N/A	May 16, 2016	1 Year
9.	DC Power Filter	JIANLI	DL-2X50B	N/A	May 16, 2016	1 Year
10.	Cable	Schwarzbeck	PLF-100	519489	May 19, 2016	1 Year
11.	Cable	Rosenberger	CIL02	A0783566	May 19, 2016	1 Year
12.	Cable	Rosenberger	RG 233/U	525178	May 19, 2016	1 Year

3.3 For Harmonic / Flicker Measurement

Item	Equipment	Manufacturer	Model No.	Serial No.	Last Cal.	Cal. Interval
1.	Power Frequency Test System	EMTEST	DPA500	U0526100506	May 16, 2016	1 Year
2.	AC Frequency Conversion Power	EMTEST	ACS 500	V526100507	May 16, 2016	1 Year
3.	PC	LENOVO	T2900D	SS12485803	May 16, 2016	1 Year

3.4 For Electrostatic Discharge Test

Item	Equipment	Manufacturer	Model No.	Serial No.	Last Cal.	Cal. Interval
1	ESD Tester	TESEQ AG	NSG437	EE166	May 16, 2016	1 Year

3.5 For RF Strength Susceptibility Test

Item	Equipment	Manufacturer	Model No.	Serial No.	Last Cal.	Cal. Interval
1.	RF Power Meter. Dual Channel	BOONTON	4232A	10539	May 16, 2016	1 Year
2.	50ohm Diode Power Sensor	BOONTON	51011EMC	34236/34238	May 16, 2016	1 Year
3.	Broad-Band Horn Antenna	SCHWARZBECK	BBHA9120 L3F	332	May 16, 2016	1 Year
4.	Power Amplifier	PRANA	AP32MT215	N/A	May 16, 2016	1 Year
5.	Power Amplifier	MILMEGA	AS0102-55	N/A	May 16, 2016	1 Year
6.	Signal Generator	AEROFLEX	2023B	N/A	May 16, 2016	1 Year
7.	Field Strength Meter	HOLADAY	HI-6005	N/A	May 16, 2016	1 Year
8.	RS232 Fiber Optic Modem	HOLADAY	HI-4413P	N/A	May 16, 2016	1 Year
9.	Log.-Per. Antenna	SCHWARZBECK	VULP 9118E	N/A	May 16, 2016	1 Year

3.6 For Electrical Fast Transient/Burst Immunity Test

Item	Equipment	Manufacturer	Model No.	Serial No.	Last Cal.	Cal. Interval
1.	Burst Tester	EM TEST	UCS500M6B	V0526100502	May 16, 2016	1 Year
2.	Coupling Clamp	EM TEST	HFK	0605-10	May 16, 2016	1 Year

3.7 For Surge Test

Item	Equipment	Manufacturer	Model No.	Serial No.	Last Cal.	Cal. Interval
1.	Surge Generator	EM TEST	VCS 500M6T	V0526100503	May 16, 2016	1 Year

3.8 For Injected Currents Susceptibility Test

Item	Equipment	Manufacturer	Model No.	Serial No.	Last Cal.	Cal. Interval
1.	Simulator	EM TEST	CWS500C	0900-12	May 16, 2016	1 Year
2.	CDN	EM TEST	CDN-M2	5100100100	May 16, 2016	1 Year
3.	CDN	EM TEST	CDN-M3	0900-11	May 16, 2016	1 Year
4.	Injection Clamp	EM TEST	F-2031-23MM	368	May 16, 2016	1 Year
5.	Attenuator	EM TEST	ATT6	0010222A	May 16, 2016	1 Year

3.9 For Magnetic Field Immunity Test

Item	Equipment	Manufacturer	Model No.	Serial No.	Last Cal.	Cal. Interval
1.	Magnetic Field Tester	HAEFELY	MAG100	250040.1	May 16, 2016	1Year

3.10 For Voltage Dips and Interruptions Test

Item	Equipment	Manufacturer	Model No.	Serial No.	Last Cal.	Cal. Interval
1.	Dips Tester	HAEFELY	Pline1610	083732-12	May 16, 2016	1 Year

4. POWER LINE CONDUCTED MEASUREMENT

4.1 Block Diagram of Test Setup

4.1.1 Block diagram of connection between the EUT and simulators

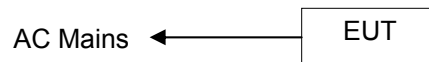

(EUT: Micro TruWireless Earbuds & Powercase)

4.1.2 Block diagram of test setup

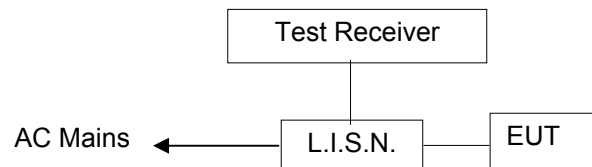

(EUT: Micro TruWireless Earbuds & Powercase)

4.2 Conducted Power Line Emission Measurement Standard and Limits

4.2.1 Standard: EN 55032: 2015

4.2.2 Limits

Frequency	At mains terminals (dB μ V)	
	Quasi-peak Level	Average Level
150KHz ~ 0.5MHz	66 ~ 56*	56 ~ 46*
0.5MHz ~ 5MHz	56	46
5.0MHz ~ 30MHz	60	50

1. At the transition frequency the lower limit applies.
2. * decreasing linearly with logarithm of the frequency.

4.3 EUT Configuration on Measurement

The configuration of the EUT is same as Section 2.1.

4.4 Operating Condition of EUT

4.4.1 Setup the EUT as shown in Section 4.1.

4.4.2 Turn on the power of all equipments.

4.4.3 Let the EUT work in measuring mode (Charging) and measure it.

4.5 Test Procedure

The EUT is put on the table which is 0.8 meter high above the ground and connected to the AC mains through a Line Impedance Stabilization Network (L.I.S.N.). This provided a 50ohm coupling impedance for the tested equipments. Both sides of AC line are checked to find out the maximum conducted emission according to the EN55032 regulations during conducted emission measurement. And the voltage probe had been used for the load terminals measurement according to the EN55032 standard.

The bandwidth of the test receiver (ESCI) is set at 200Hz in 9K~150KHz range and 9KHz in 150K~30MHz range.

The frequency range from 150KHz to 30MHz is checked.

4.6 Measurement Results

PASS.

The frequency range from 150KHz to 30MHz is investigated.

The test data are listed the following pages.

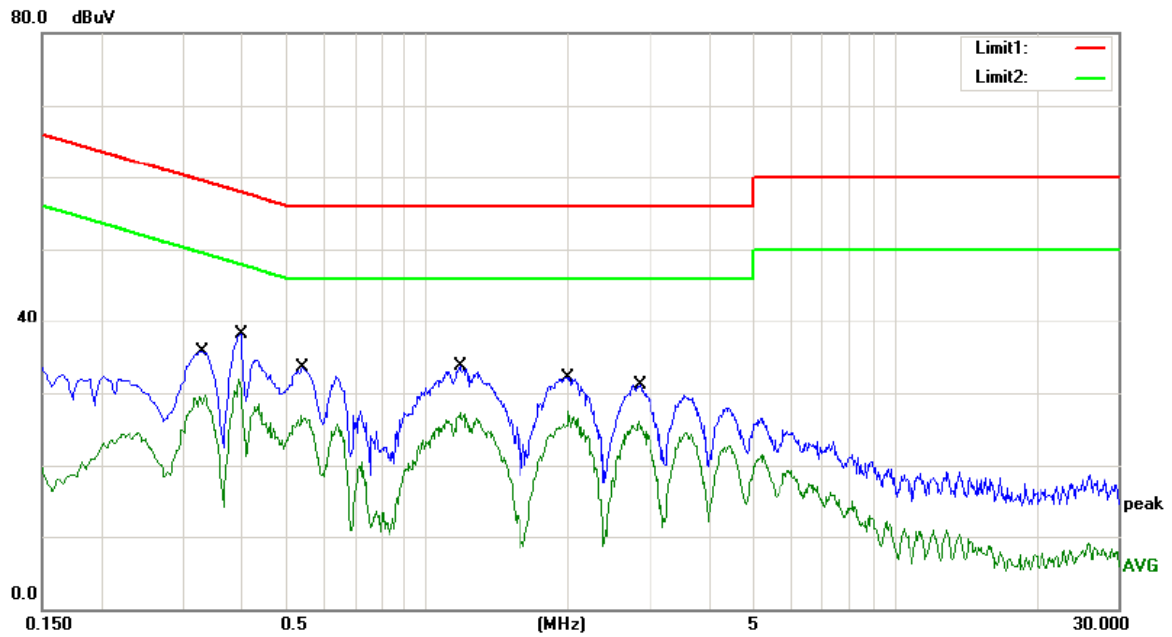

Site site #1 Phase: **L1** Temperature: 24
 Limit: (CE)EN55032 class B_QP Power: AC 230V/50Hz Humidity: 55 %
 Mode: Charging
 Note:

No.	Mk.	Freq. MHz	Reading Level dBuV	Correct Factor dB	Measure- ment dBuV	Limit dBuV	Over dB	Detector	Comment
1		0.3300	25.73	10.06	35.79	59.45	-23.66	QP	
2		0.3300	19.58	10.06	29.64	49.45	-19.81	AVG	
3		0.3940	28.11	10.07	38.18	57.98	-19.80	QP	
4	*	0.3940	21.81	10.07	31.88	47.98	-16.10	AVG	
5		0.5380	23.37	10.10	33.47	56.00	-22.53	QP	
6		0.5380	16.73	10.10	26.83	46.00	-19.17	AVG	
7		1.1740	23.64	10.10	33.74	56.00	-22.26	QP	
8		1.1740	17.13	10.10	27.23	46.00	-18.77	AVG	
9		1.9980	21.96	10.10	32.06	56.00	-23.94	QP	
10		1.9980	17.38	10.10	27.48	46.00	-18.52	AVG	
11		2.8260	20.97	10.10	31.07	56.00	-24.93	QP	
12		2.8260	16.02	10.10	26.12	46.00	-19.88	AVG	

*:Maximum data x:Over limit !:over margin Comment: Factor build in receiver. Operator: Aspen

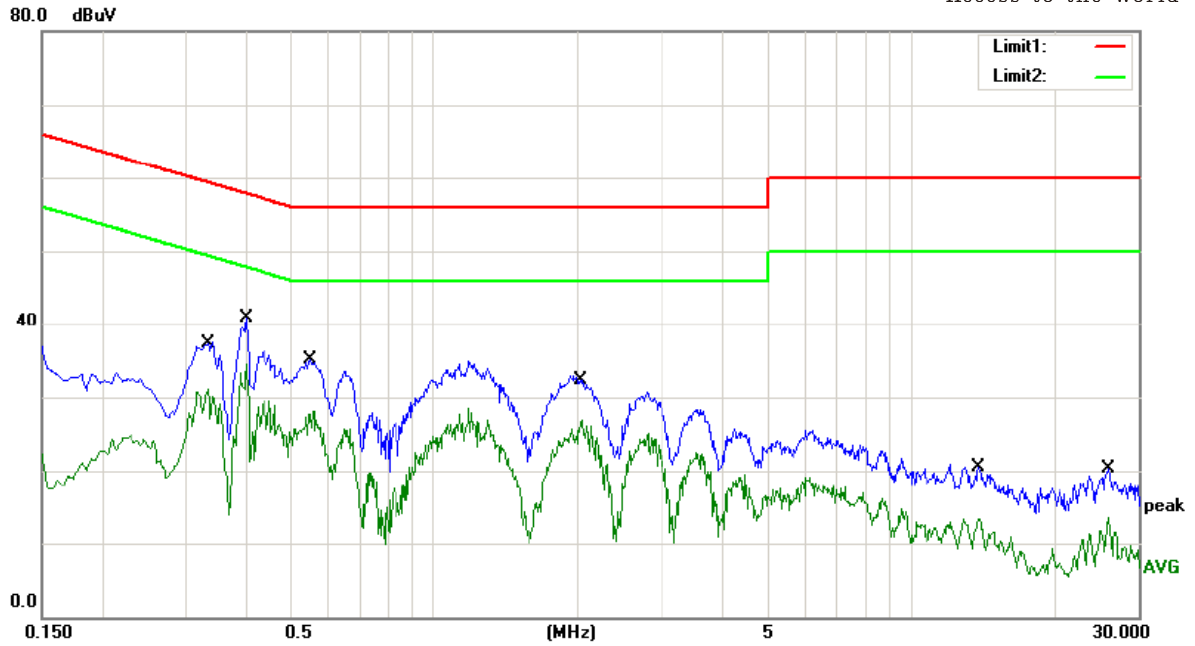

Site site #1

Phase: **N**

Temperature: 24

Limit: (CE)EN55032 class B_QP

Power: AC 230V/50Hz

Humidity: 55 %

Mode: Charging

Note:

No.	Mk.	Freq.	Reading Level	Correct Factor	Measurement	Limit	Over	Detector	Comment
		MHz	dBuV	dB	dBuV	dBuV	dB		
1		0.3340	27.39	10.06	37.45	59.35	-21.90	QP	
2		0.3340	21.13	10.06	31.19	49.35	-18.16	AVG	
3		0.4020	30.76	10.07	40.83	57.81	-16.98	QP	
4	*	0.4020	24.42	10.07	34.49	47.81	-13.32	AVG	
5		0.5500	25.09	10.10	35.19	56.00	-20.81	QP	
6		0.5500	17.99	10.10	28.09	46.00	-17.91	AVG	
7		2.0260	22.24	10.10	32.34	56.00	-23.66	QP	
8		2.0260	16.71	10.10	26.81	46.00	-19.19	AVG	
9		13.8820	10.24	10.27	20.51	60.00	-39.49	QP	
10		13.8820	3.08	10.27	13.35	50.00	-36.65	AVG	
11		25.9820	9.75	10.50	20.25	60.00	-39.75	QP	
12		25.9820	2.94	10.50	13.44	50.00	-36.56	AVG	

*:Maximum data x:Over limit !:over margin Comment: Factor build in receiver. Operator: Aspen

5. RADIATED EMISSION MEASUREMENT

5.1 Block Diagram of Test

5.1.1 Block diagram of connection between the EUT and simulators

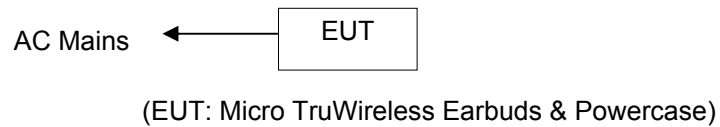

5.1.2 Block diagram of test setup (In chamber)

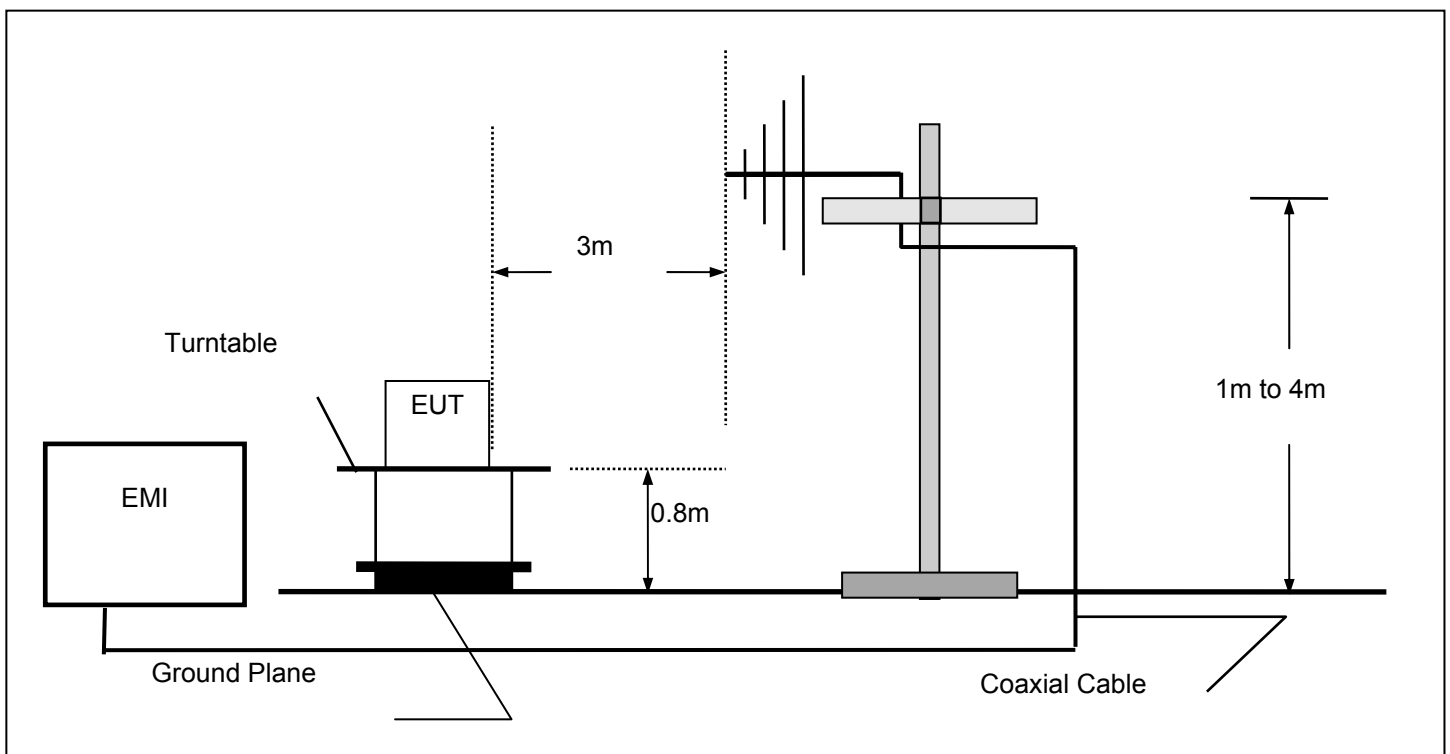

(EUT: Micro TruWireless Earbuds & Powercase)

5.2 Measuring Standard

EN 55032: 2015

5.3 Radiated Emission Limits

All emanations from a device or system, including any network of conductors and apparatus connected thereto, shall not exceed the level of field strengths specified below:

Limits below 1GHz

FREQUENCY (MHz)	DISTANCE (Meters)	FIELD STRENGTHS LIMIT (dB μ V/m)
30 ~ 230	3	40
230 ~ 1000	3	47

- Note: (1) The smaller limit shall apply at the combination point between two frequency bands.
(2) Distance refers to the distance in meters between the measuring instrument antenna and the closed point of any part of the EUT.

5.4 EUT Configuration on Test

The EN55032 regulations test method must be used to find the maximum emission during radiated emission measurement.

EUT : Micro TruWireless Earbuds & Powercase
Model Number : 7199-99

5.5 Operating Condition of EUT

5.5.1 Turn on the power.

5.5.2 Let the EUT work in test mode (Charging) and measure it.

5.6 Test Procedure

The EUT is placed on a turn table which is 0.8 meter high above the ground. The turn table can rotate 360 degrees to determine the position of the maximum emission level. The EUT is set 3 meters away from the receiving antenna which is mounted on a antenna tower. The antenna can be moved up and down from 1 to 4 meters to find out the maximum emission level. Bilog antenna (calibrated by Dipole Antenna) is used as a receiving antenna. Both horizontal and vertical polarization of the antenna are set on test.

The bandwidth of the Receiver (ESCI) is set at 120kHz.

5.7 Test Results

PASS.

The frequency range from 30MHz to 6000MHz is investigated.

The test data are listed the following pages.

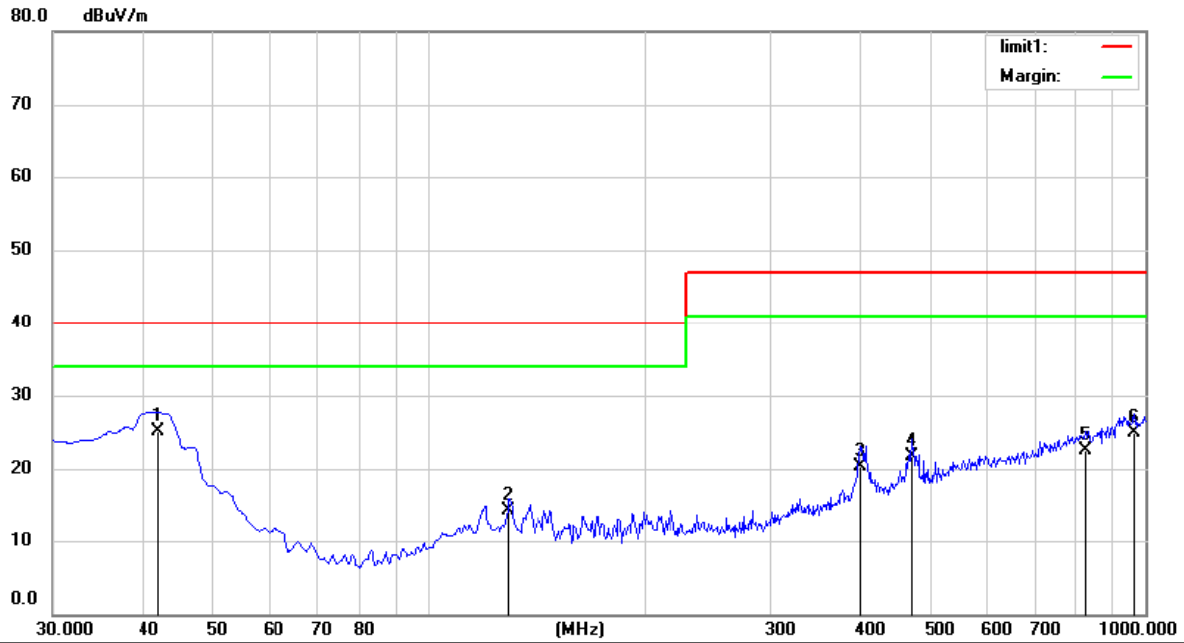

Site Chamber #1 Polarization: **Vertical** Temperature: 26
 Limit: (RE)EN55032_class B_3m Power: AC 230V/60Hz Humidity: 55 %
 Mode: Charging
 Note:

No.	Mk.	Freq.	Reading Level	Correct Factor	Measurement	Limit	Over	Antenna Height	Table Degree	
		MHz	dBuV	dB	dBuV/m	dBuV/m	dB	cm	degree	Comment
1	*	42.0066	38.23	-13.05	25.18	40.00	-14.82	QP		
2		129.4677	31.52	-17.51	14.01	40.00	-25.99	QP		
3		400.4318	32.15	-11.79	20.36	47.00	-26.64	QP		
4		472.1760	32.66	-10.95	21.71	47.00	-25.29	QP		
5		827.4934	26.85	-4.41	22.44	47.00	-24.56	QP		
6		965.5420	27.16	-2.16	25.00	47.00	-22.00	QP		

*:Maximum data x:Over limit !:over margin

Operator: W

6. HARMONIC CURRENT MEASUREMENT

6.1 Block Diagram of Test Setup

6.1.1 Block diagram of connection between the EUT and simulators

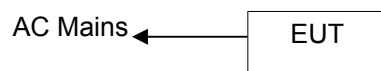

(EUT: Micro TruWireless Earbuds & Powercase)

6.1.2 Block Diagram of Harmonic Test Setup

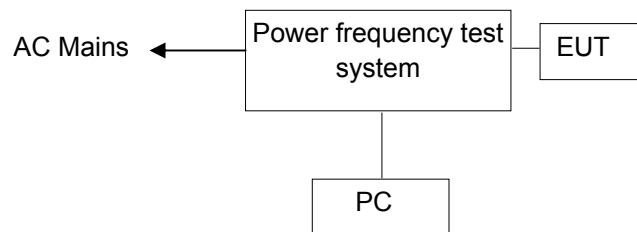

(EUT: Micro TruWireless Earbuds & Powercase)

6.2 Measuring Standard

EN 61000-3-2: 2014 Class A Power \leq 75W

6.3 Operating Condition of EUT

Same as Section 4.4. Except the test setup replaced by Section 6.1.

6.4 Test Results

N/A.

Because power of EUT is less than 75W, according to standard EN61000-3-2, Harmonics Current is not required.

7. VOLTAGE FLUCTUATIONS & FLICKER MEASUREMENT

7.1 Block Diagram of Test Setup

7.1.1 Block diagram of connection between the EUT and simulators

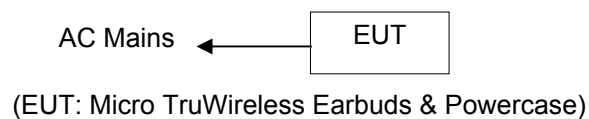

7.1.2 Block Diagram of Flicker Test Setup

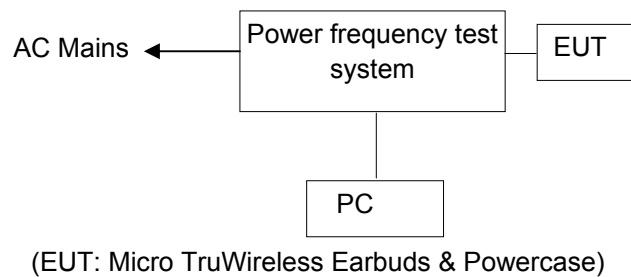

7.2 Measuring Standard

EN 61000-3-3: 2013

7.3 Operating Condition of EUT

Same as Section 4.4 except the test setup replaced by Section 7.1.

7.4 Test Results

PASS.

Please refer to the following pages.

Test Report

Report title:	Flicker
Company Name:	EMTEK
Date of test:	8:40 11.April 2017
Tester:	Snake
Standard used:	EN/IEC 61000-3-3 Flicker
Short time (Pst):	10 min
Observation time:	10 min (1 Flicker measurement)
Flickermeter:	230V / 50Hz
Flicker Impedance:	Zref (IEC 60725)
Customer:	USC056 Micro TruWireless Earbuds & Powercase
E. U. T.:	

Test Result	PASS
-------------	------

Maximum Flicker results

	EUT values	Limit	Result
Pst	0.028	1.00	PASS
Plt	0.028	0.65	PASS
dc [%]	0.005	3.30	PASS
dmax [%]	0.214	4.00	PASS
dt [s]	0.000	0.50	PASS

8. ELECTROSTATIC DISCHARGE TEST

8.1 Block Diagram of Test Setup

8.1.1 Block diagram of connection between the EUT and simulators

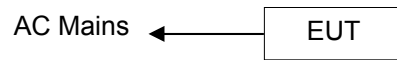

(EUT: Micro TruWireless Earbuds & Powercase)

8.1.2 Block Diagram of ESD Test Setup

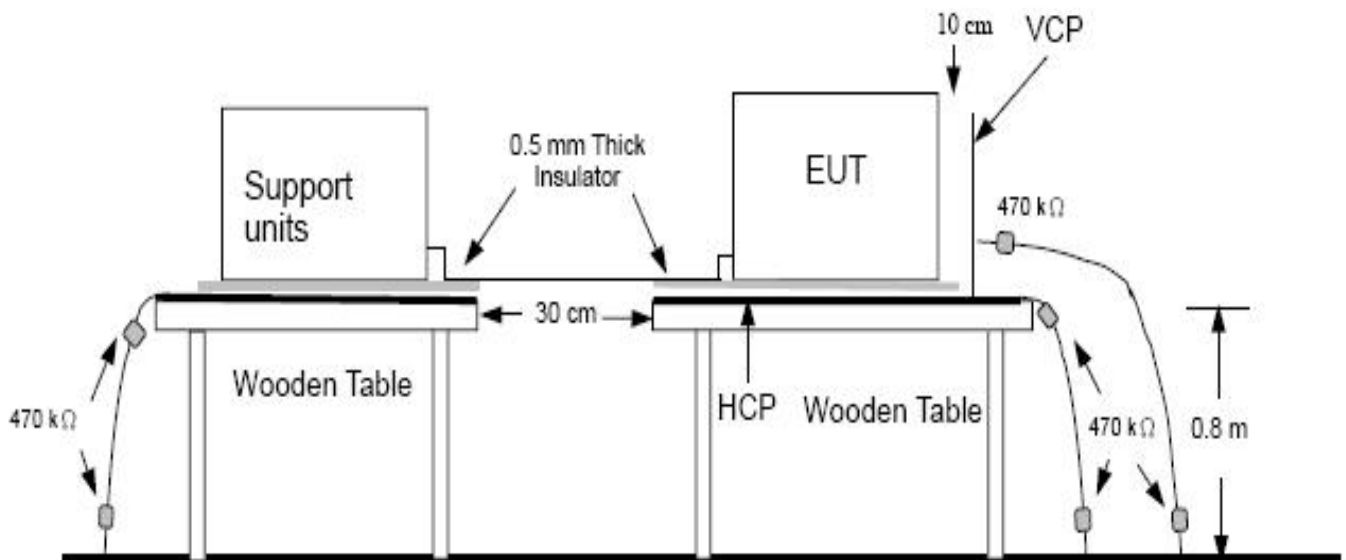

Ground Reference Plane

(EUT: Micro TruWireless Earbuds & Powercase)

8.2 Test Standard

EN 55024: 2010+A1: 2015
(IEC 61000-4-2: 2008 (Severity Level: 2 /Contact Discharge: $\pm 4\text{KV}$
Severity Level: 3 / Air Discharge: $\pm 8\text{KV}$))

8.3 Severity Levels and Performance Criterion

8.3.1 Severity level

Level	Test Voltage Contact Discharge (KV)	Test Voltage Air Discharge (KV)
1.	±2	±2
2.	±4	±4
3.	±6	±8
4.	±8	±15
X	Special	Special

8.3.2 Performance criterion: **B**

8.4 EUT Configuration

The configuration of EUT is listed in Section 2.1

8.5 Operating Condition of EUT

8.5.1 Setup the EUT as shown in Section 8.1.

8.5.2 Turn on the power of all equipments.

8.5.3 Let the EUT work in test mode (Charging) and measure it.

8.6 Test Procedure

8.6.1 Air Discharge:

This test is done on a non-conductive surfaces. The round discharge tip of the discharge electrode shall be approached as fast as possible to touch the EUT. After each discharge, the discharge electrode shall be removed from the EUT. The generator is then re-triggered for a new single discharge and repeated 25 times for each pre-selected test point. This procedure shall be repeated until all the air discharge completed.

8.6.2 Contact Discharge:

All the procedure shall be same as Section 8.6.1. except that the tip of the discharge electrode shall touch the EUT before the discharge switch is operated.

8.6.3 Indirect discharge for horizontal coupling plane:

At least 20 single discharges shall be applied to the horizontal coupling plane, at points on each side of the EUT. The discharge electrode positions vertically at a distance of 0.1m from the EUT and with the discharge electrode touching the coupling plane.

8.6.4 Indirect discharge for vertical coupling plane:

At least 20 single discharge shall be applied to the center of one vertical edge of the coupling plane. The coupling plane, of dimensions 0.5m X 0.5m, is placed parallel to, and positioned at a distance of 0.1m from the EUT. Discharges shall be applied to the coupling plane, with this plane in sufficient different positions that the four faces of the EUT are completely illuminated.

8.7 Test Results

PASS.

Please refer to the following page.

9. RF FIELD STRENGTH SUSCEPTIBILITY TEST

9.1 Block Diagram of Test Setup

9.1.1 Block diagram of connection between the EUT and simulators

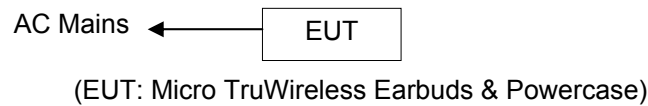

9.1.2 Block diagram of R/S test set up

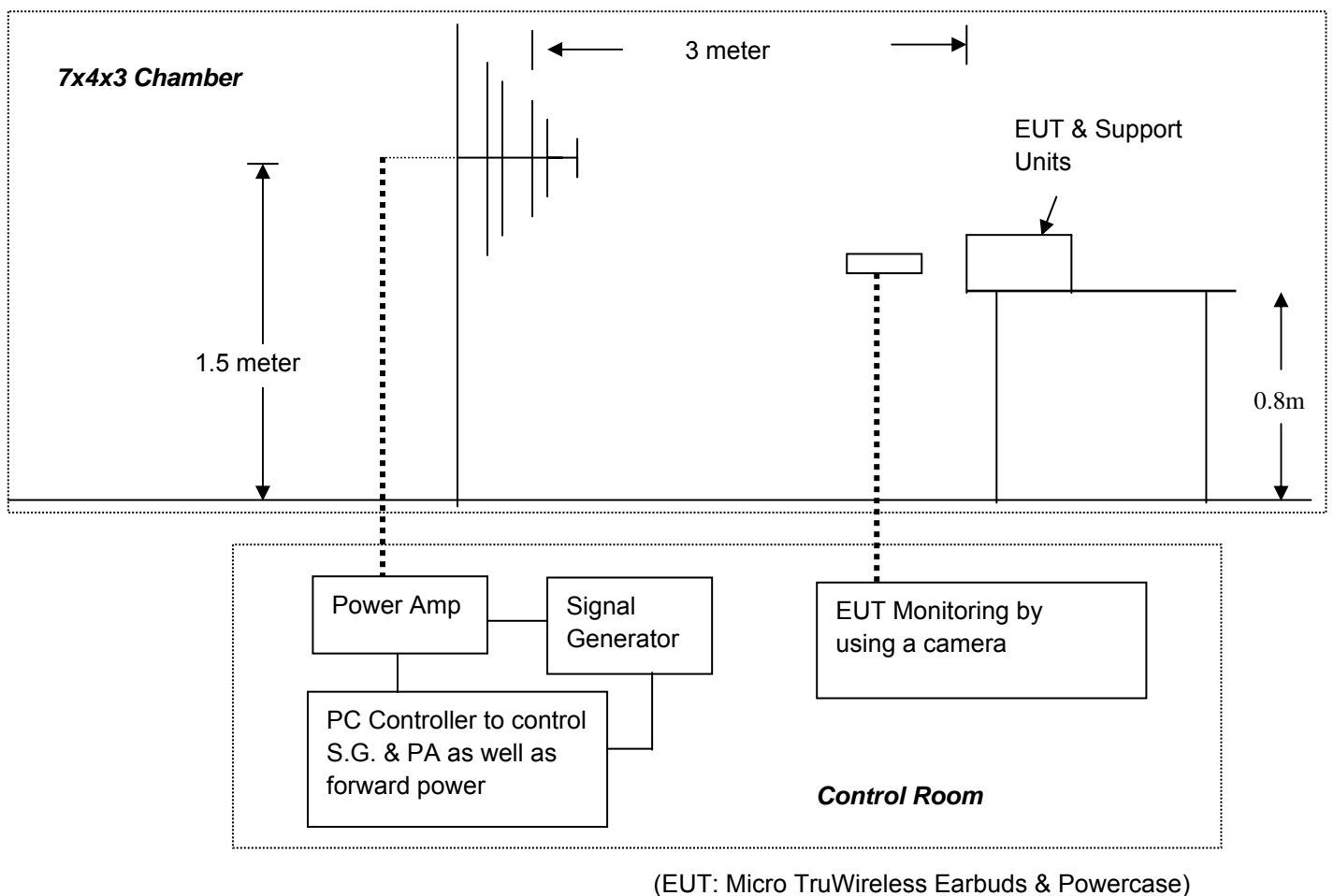

9.2 Test Standard

EN 55024: 2010+A1: 2015
(IEC 61000-4-3: 2006+A1: 2007+A2: 2010 (Severity Level 2, 3V / m))

9.3 Severity Levels and Performance Criterion

9.3.1 Severity level

Level	Field Strength V/m
1.	1
2.	3
3.	10
X	Special

9.3.2 Performance criterion: **A**

9.4 EUT Configuration

The configuration of EUT are listed in Section 2.1.

9.5 Operating Condition of EUT

9.5.1 Setup the EUT as shown in Section 9.1.

9.5.2 Turn on the power of all equipments.

9.5.3 Let the EUT work in test mode (Charging) and measure it.

9.6 Test Procedure

The EUT and its simulators are placed on a turn table which is 0.8 meter above ground. EUT is set 3 meter away from the transmitting antenna which is mounted on an antenna tower. Both horizontal and vertical polarization of the antenna are set on test. Each of the four sides of EUT must be faced this transmitting antenna and measured individually. In order to judge the EUT performance, a CCD camera is used to monitor EUT screen. All the scanning conditions are as follows:

Condition of Test	Remarks
1. Fielded Strength	3 V/m (Severity Level 2)
2. Radiated Signal	Unmodulated
3. Scanning Frequency	80 - 1000 MHz
4. Dwell time of radiated	0.0015 decade/s
5. Waiting Time	1 Sec.

9.7 Test Results

PASS.

These test result outsourced to EMTEK(SHENZHEN) CO., LTD.

Please refer to the following page.

RF Field Strength Susceptibility Test Results

EMTEK(SHENZHEN) CO., LTD.

Applicant: USC056 Test Date : April 14, 2017
 EUT : Micro TruWireless Earbuds & Powercase Temperature : 25°C
 M/N : 7199-99 Humidity : 50%
 Field Strength: 3 V/m Criterion: A
 Power Supply: AC 230V/50Hz Frequency Range: 80 - 1000MHz
 Test Engineer: Lin
 Modulation: AM Pulse none 1 KHz 80%
 Test Mode : Charging

Frequency Rang : 80 - 1000MHz		
Steps	1 %	
	Horizontal	Vertical
Front	PASS	PASS
Right	PASS	PASS
Rear	PASS	PASS
Left	PASS	PASS

Test Equipment :

1. Signal Generator : 2023B (AEROFLEX)
2. Power Amplifier : AS0102-55 (MILMEGA)& AP32MT215 (PRANA)
3. Log.-Per. Antenna: VULP 9118E(SCHWARZBECK)
4. Broad-Band Horn Antenna: BBHA9120L3F (SCHWARZBECK)
5. RF Power Meter. Dual Channel : 4232A (BOONTON)
6. Field Strength Meter: HI-6005(HOLADAY)

Note:

10. ELECTRICAL FAST TRANSIENT/BURST TEST

10.1 Block Diagram of Test Setup

10.1.1 Block Diagram of connection between the EUT and simulators

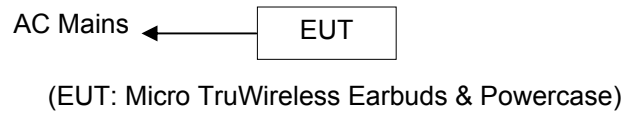

10.1.2 Block Diagram of EFT Test Setup

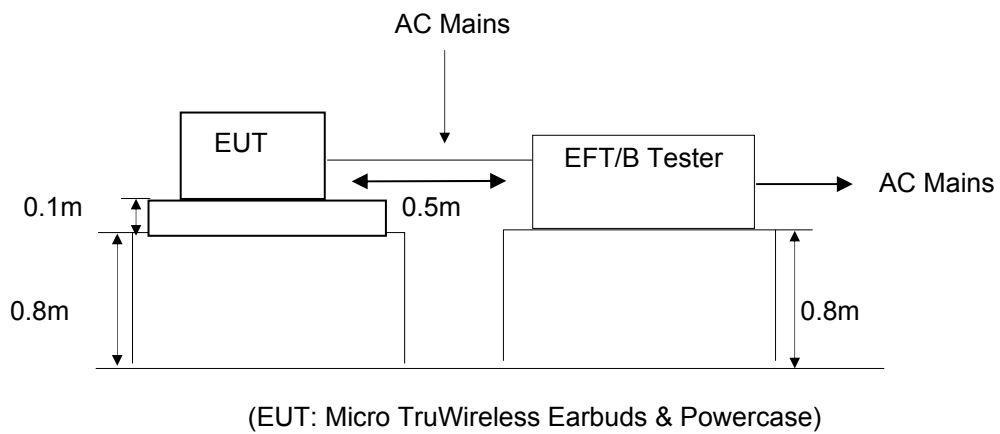

10.2 Test Standard

EN 55024: 2010+A1: 2015
(IEC 61000-4-4: 2012, Severity Level, Level 2: 1KV)

10.3 Severity Levels and Performance Criterion

10.3.1 Severity level

Open circuit output test voltage and repetition rate of the impulses				
Level	On power port, PE		On I/O (Input/Output) Signal data and control ports	
	Voltage peak KV	Repetition rate KHz	Voltage peak KV	Repetition rate KHz
1.	0.5 KV	5 or 100	0.25 KV	5 or 100
2.	1 KV	5 or 100	0.5 KV	5 or 100
3.	2 KV	5 or 100	1 KV	5 or 100
4.	4 KV	5 or 100	2 KV	5 or 100
X	Special	Special	Special	Special
NOTE 1 Use of 5 KHz repetition rates is traditional; however, 100 KHz is closer to reality. Product committees should determine which frequencies are relevant for specific products or product types.				
NOTE 2 With some products, there may be no clear distinction, between power ports and I/O ports, in which case it is up to product committees to make this determination for test purposes.				
"X" is an open level. The level has to be specified in the dedicated equipment specification.				

10.3.2 Performance criterion: B

10.4 EUT Configuration

The configuration of EUT are listed in Section 2.1.

10.5 Operating Condition of EUT

- 10.5.2 Setup the EUT as shown in Section 10.1.
- 10.5.3 Turn on the power of all equipments.
- 10.5.4 Let the EUT work in test mode (Charging) and measure it.

10.6 Test Procedure

The EUT is put on the table which is 0.8 meter high above the ground. This reference ground plane shall project beyond the EUT by at least 0.1m on all sides and the minimum distance between EUT and all other conductive structure, except the ground plane beneath the EUT, shall be more than 0.5m.

10.6.2 For input and output AC power ports:

The EUT is connected to the power mains by using a coupling device which couples the EFT interference signal to AC power lines. Both polarities of the test voltage should be applied during compliance test and the duration of the test is 2 mins.

10.6.3 For signal lines and control lines ports:

No I/O ports. It's unnecessary to test.

10.7 Test Results

PASS.

Please refer to the following page.

Electrical Fast Transient/Burst Test Results

EMTEK(DONGGUAN) CO., LTD.

Standard :	<input checked="" type="checkbox"/> IEC 61000-4-4 <input type="checkbox"/> EN 61000-4-4	Result : <input checked="" type="checkbox"/> PASS / <input type="checkbox"/> FAIL	
Applicant : <u>USC056</u>			
EUT : <u>Micro TruWireless Earbuds & Powercase</u>			
M/N : <u>7199-99</u>			
Input Voltage: <u>AC 230V/50Hz</u>			
Criterion : <u>B</u>			
Ambient Condition : <u>25 °C</u> <u>50% RH</u>			
Operation Mode : Charging			
Line : <input checked="" type="checkbox"/> AC Mains	Line : <input type="checkbox"/> Signal <input type="checkbox"/> I/O Cable		
Coupling : <input checked="" type="checkbox"/> Direct	Coupling : <input type="checkbox"/> Capacitive		
Test Time : 120s			
Line	Test Voltage	Result (+)	Result (-)
L	1KV	PASS	PASS
N	1KV	PASS	PASS
PE			
L、N	1KV	PASS	PASS
L、PE			
N、PE			
L、N、PE			
Signal Line			
DC Line			
Note:			
Test Equipment		Burst Tester Model : UCS500M6B	

11. SURGE IMMUNITY TEST

11.1 Block Diagram of Test Setup

11.1.1 Block Diagram of the EUT

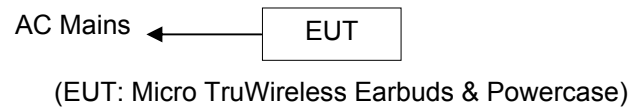

11.1.2 Surge Test Setup

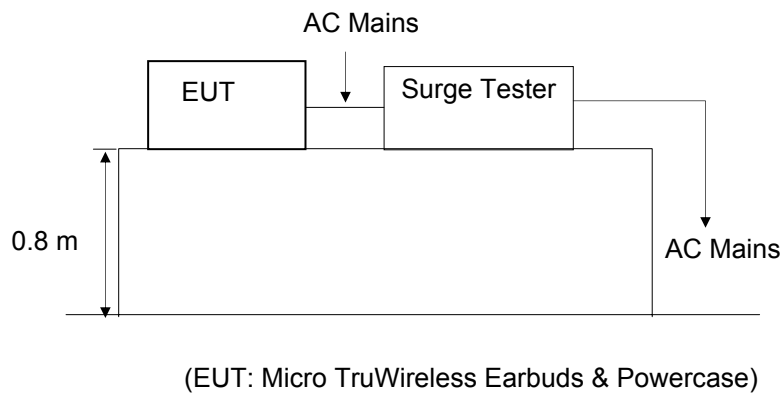

11.2 Test Standard

EN 55024: 2010+A1: 2015

(IEC 61000-4-5: 2014, Severity Level: Line to Line: Level 2, 1.0KV)

11.3 Severity Levels and Performance Criterion

11.3.1 Severity level

Severity Level	Open-Circuit Test Voltage KV
1	0.5
2	1.0
3	2.0
4	4.0
*	Special

11.3.2 Performance criterion: **B**

11.4 EUT Configuration

The configuration of EUT are listed in Section 2.1.

11.5 Operating Condition of EUT

11.5.1 Setup the EUT as shown in Section 11.1.

11.5.2 Turn on the power of all equipments.

11.5.3 Let the EUT work in test mode (Charging) and measure it.

11.6 Test Procedure

- 1) Set up the EUT and test generator as shown on Section 11.1.2.
- 2) For line to line coupling mode, provide a 1.0KV 1.2/50us voltage surge (at open-circuit condition) and 8/20us current surge to EUT selected points.
- 3) At least 5 positive and 5 negative (polarity) tests with a maximum 1/min repetition rate are conducted during test.
- 4) Different phase angles are done individually.
- 5) Record the EUT operating situation during compliance test and decide the EUT immunity criterion for above each test.

11.7 Test Results

PASS.

Please refer to the following page.

12. INJECTED CURRENTS SUSCEPTIBILITY TEST

12.1 Block Diagram of Test Setup

12.1.1 Block Diagram of the EUT

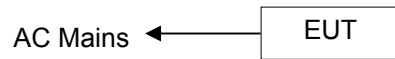

(EUT: Micro TruWireless Earbuds & Powercase)

12.1.2 Block Diagram of Test Setup

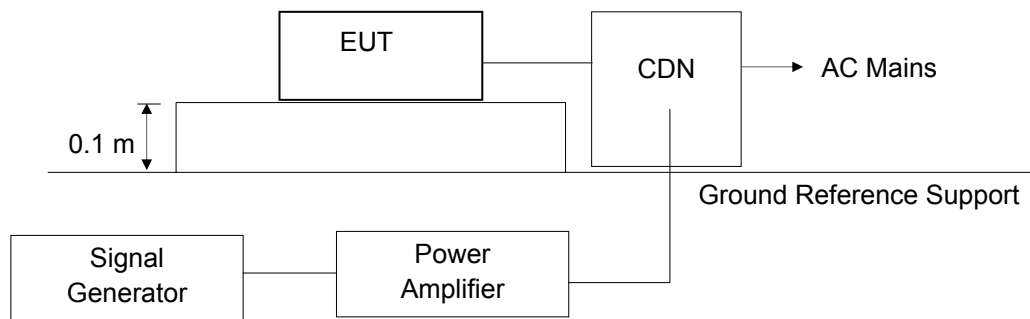

(EUT: Micro TruWireless Earbuds & Powercase)

12.2 Test Standard

EN 55024: 2010+A1: 2015

(IEC 61000-4-6: 2008, Severity Level 2: 3V (rms), 0.15MHz ~ 80MHz)

12.3 Severity Levels and Performance Criterion

12.3.1 Severity level

Level	Field Strength V
1.	1
2.	3
3.	10
X	Special

12.3.2 Performance criterion: **A**

12.4 EUT Configuration

The configuration of EUT are listed in Section 2.1.

12.5 Operating Condition of EUT

12.5.2 Setup the EUT as shown in Section 12.1.

12.5.3 Turn on the power of all equipments.

12.5.4 Let the EUT work in test mode (Charging) and measure it.

12.6 Test Procedure

- 1) Set up the EUT, CDN and test generators as shown on Section 12.1.2.
- 2) Let the EUT work in test mode and measure it.
- 3) The EUT are placed on an insulating support 0.1m high above a ground reference plane. CDN (coupling and decoupling device) is placed on the ground plane about 0.3m from EUT. Cables between CDN and EUT are as short as possible, and their height above the ground reference plane shall be between 30 and 50 mm (where possible).
- 4) The disturbance signal described below is injected to EUT through CDN.
- 5) The EUT operates within its operational mode(s) under intended climatic conditions after power on.
- 6) The frequency range is swept from 150KHz to 80MHz using 3V signal level, and with the disturbance signal 80% amplitude modulated with a 1KHz sine wave.
- 7) The rate of sweep shall not exceed $1.5 \cdot 10^{-3}$ decades/s. Where the frequency is swept incrementally, the step size shall not exceed 1% of the start and thereafter 1% of the preceding frequency value.
- 8) Recording the EUT operating situation during compliance testing and decide the EUT immunity criterion.

12.7 Test Results

PASS.

These test result outsourced to EMTEK(SHENZHEN) CO., LTD.

Please refer to the following page.

Injected Currents Susceptibility Test Results

EMTEK(SHENZHEN) CO., LTD.

Applicant : <u>USC056</u>			Test Date : <u>April 14, 2017</u>	
EUT : <u>Micro TruWireless Earbuds & Powercase</u>			Temperature : <u>25°C</u>	
M/N : <u>7199-99</u>			Humidity : <u>50%</u>	
Power Supply : <u>AC 230V/50Hz</u>			Test Engineer : <u>Andy</u>	
Test Mode : <u>Charging</u>				
Frequency Range (MHz)	Injected Position	Strength	Criterion	Result
0.15 ~ 80	AC Mains	3V(rms),	A	PASS
Test Mode : _____				
Frequency Range (MHz)	Injected Position	Strength	Criterion	Result
Remark : 1. Modulation Signal:1KHz 80% AM Measurement Equipment : Simulator: CWS 500C (SWITZERLAND EMTEST) CDN : <input checked="" type="checkbox"/> CDN-M2 (SWITZERLAND EMTEST) <input type="checkbox"/> CDN-M3 (SWITZERLAND EMTEST)			Note:	

13. VOLTAGE DIPS AND INTERRUPTIONS TEST

13.1 Block Diagram of Test Setup

13.1.1 Block Diagram of the EUT

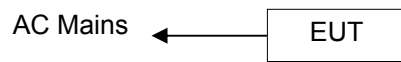

(EUT: Micro TruWireless Earbuds & Powercase)

13.1.2 Dips Test Setup

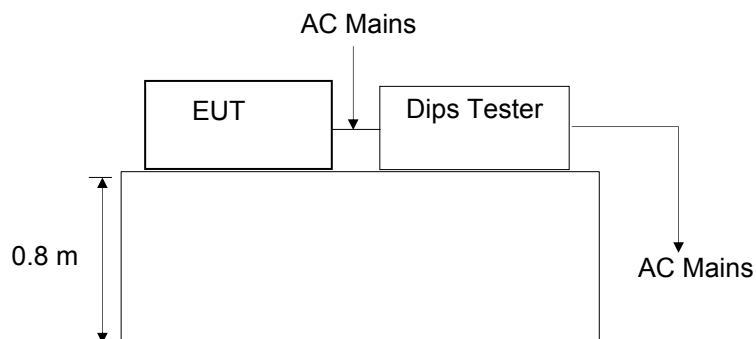

(EUT: Micro TruWireless Earbuds & Powercase)

13.2 Test Standard

EN 55024: 2010+A1: 2015
(IEC 61000-4-11: 2004)

13.3 Severity Levels and Performance Criterion

13.3.1 Severity level

Test Level %UT	Voltage dip and short interruptions %UT	Duration (in period)
0	100	0.5
40	60	1
70	30	5
		10
		25
		50
		*

13.3.2 Performance criterion: **B, C**

13.4 EUT Configuration

The configuration of EUT are listed in Section 2.1.

13.5 Operating Condition of EUT

- 13.5.1 Setup the EUT as shown in Section 14.1.
- 13.5.2 Turn on the power of all equipments.
- 13.5.3 Let the EUT work in test mode (Charging) and measure it.

13.6 Test Procedure

- 1) Set up the EUT and test generator as shown on Section 14.1.2.
- 2) The interruptions is introduced at selected phase angles with specified duration.
- 3) Record any degradation of performance.

13.7 Test Results

PASS.

These test result outsourced to EMTEK(SHENZHEN) CO., LTD.

Please refer to the following page.

Voltage Dips And Interruptions Test Results

EMTEK(SHENZHEN) CO., LTD.

Applicant : <u>USC056</u>			Test Date : <u>April 14, 2017</u>	
EUT : <u>Micro TruWireless Earbuds & Powercase</u>			Temperature : <u>25°C</u>	
M/N : <u>7199-99</u>			Humidity : <u>50%</u>	
Power Supply : <u>AC 230V/50Hz</u>			Test Engineer : <u>Andy</u>	
Test Model : <u>Charging</u>				
Test Level % U _T	Voltage Dips & Short Interruptions % U _T	Duration (in period)	Criterion <input type="checkbox"/> A <input checked="" type="checkbox"/> B <input checked="" type="checkbox"/> C <input type="checkbox"/> D	Result
70	30	25P	C	PASS
0	100	250P	C	PASS
0	100	0.5P	B	PASS
Test Model : _____				
Test Level % U _T	Voltage Dips & Short Interruptions % U _T	Duration (in period)	Criterion <input type="checkbox"/> A <input checked="" type="checkbox"/> B <input checked="" type="checkbox"/> C <input type="checkbox"/> D	Result
Remark: U _T is the rated voltage for the equipment.			Test Equipment : Dips Tester PLINE1610	

14. PHOTOGRAPH

14.1 Photo of Conducted Emission Measurement



14.2 Photo of Radiation Emission Measurement

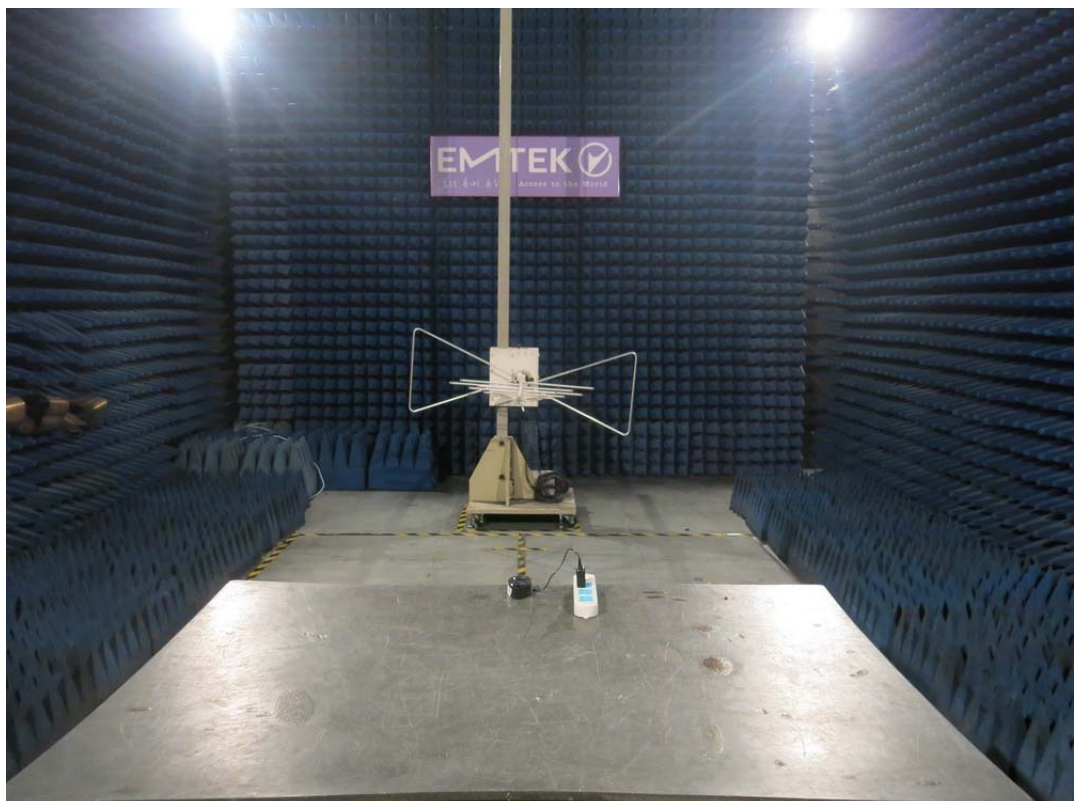

14.3 Photo of Harmonic/Flicker Measurement



14.4 Photo of Electrostatic Discharge Test



14.5 Photo of RF Field Strength susceptibility Test

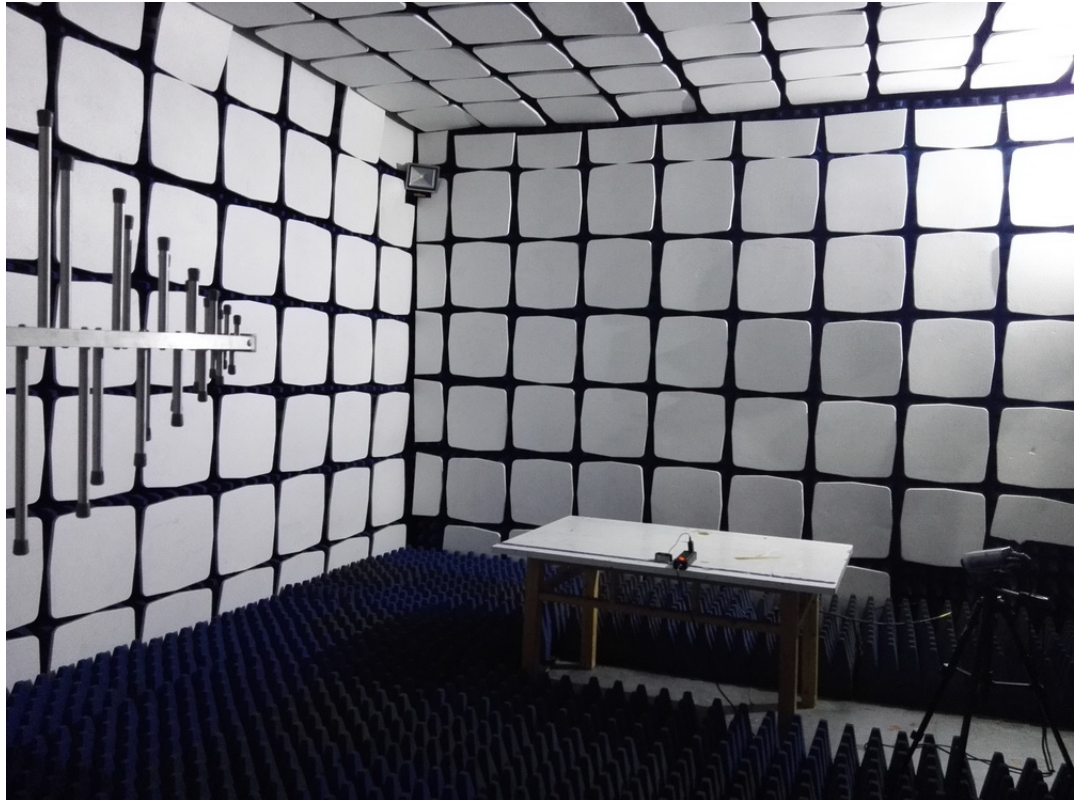

14.6 Photo of Electrical Fast Transient /Burst Test



14.7 Photo of Surge Test



14.8 Photo of Injected Currents Susceptibility Test

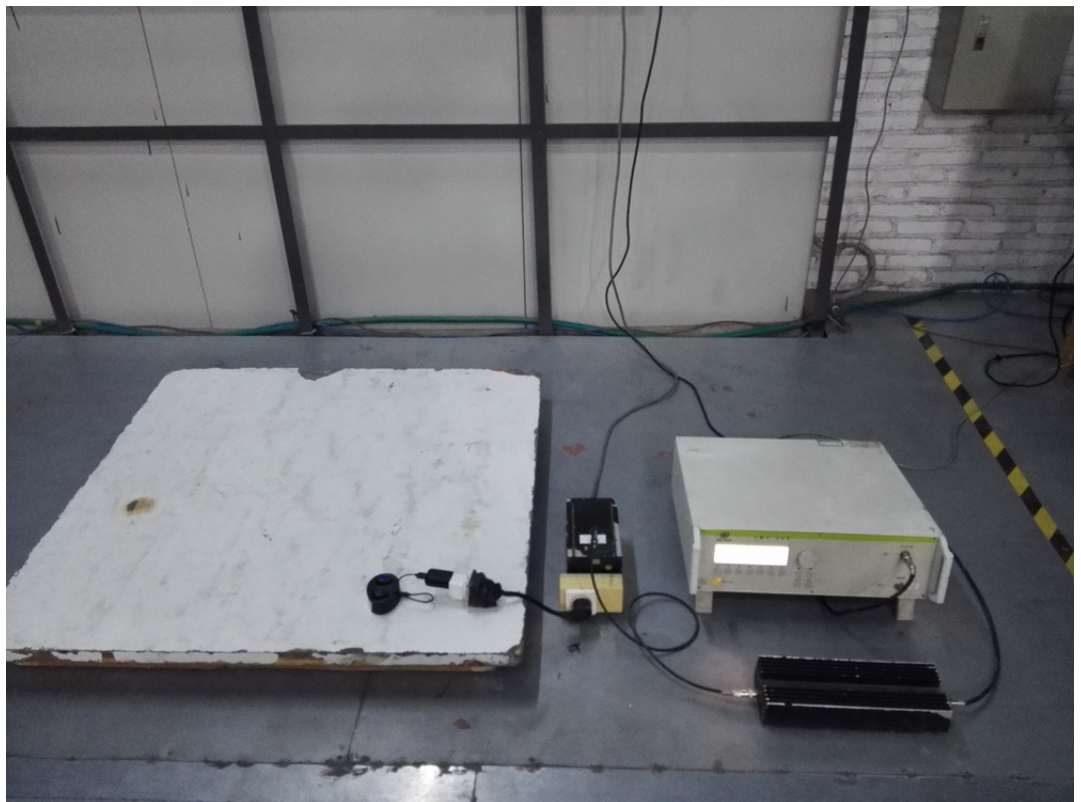

14.9 Photo of Voltage Dips and Interruption Immunity Test



APPENDIX I (Photos of EUT)



